

# Construction Consents

## Standard Construction Details

Date Created: 19<sup>th</sup> August 2019

Revision: 8

Revision Date: 31st July 2023

### INTRODUCTION

North Ayrshire Council has produced a set of standard details that can be used in the submission of construction consents within North Ayrshire. Our standard construction details provide useful information for construction consent applications. These can either be duplicated for consents within the area or referenced in any submitted consent. The developer is responsible for ensuring that the standard details are relevant for their construction consent submission.

If the standard details are copied into construction consent submissions, please add the following to the drawings.

*"The standard details (Revision X) within this submission are obtained from North Ayrshire Council's standard details, with their permission. North Ayrshire Council disclaim all responsibility and accept no liability (including in negligence) for the consequences for any person using these standard details."*

### NORTH AYRSHIRE COUNCIL - LIST OF STANDARD DRAWINGS

No.	Code	Drawing No.	Title	Revision	Date
001	CD	NAC/001/CD	STANDARD FOOTWAY/CARRIAGEWAY CONSTRUCTION DEPTHS	A	19/08/19
<b>Kerb Details</b>					
101	HB1	NAC/101/HB1	PRECAST CONCRETE KERB TYPES STANDARD 125x255mm HALF BATTER KERB (HB1)	A	19/08/19
102	SP1	NAC/102/SP1	PRECAST CONCRETE KERB TYPES STANDARD 125x255mm SPLAYED KERB (SP1)	A	19/08/19
103	BN1 - 4	NAC/103/BNK	PRECAST CONCRETE KERB TYPES STANDARD 125x255mm BULLNOSED KERB (Various Upstand)	A	19/08/19
104	BN5	NAC/104/BN5	PRECAST CONCRETE KERB TYPES STANDARD 125x150mm BULLNOSED KERB (BN5)	A	19/08/19
105	CS	NAC/105/CS	PRECAST CONCRETE KERB TYPES STANDARD 125x225mm SQUARE CHANNEL KERB (CS)	A	19/08/19
106	RT	NAC/106/RT	PRECAST CONCRETE KERB TYPES STANDARD 50x150mm ROUND TOP EDGING KERB (RT)	A	19/08/19
107	FT	NAC/107/FT	PRECAST CONCRETE KERB TYPES STANDARD 50x150mm FLAT TOP EDGING KERB (FT)	A	19/08/19

108	TR	NAC/108/TR	PRECAST CONCRETE KERB TYPES STANDARD TRIEF KERB (TR)	A	19/08/19
<b>Typical Sections</b>					
201	FCA	NAC/201/FCA	STREET TYPE 1, 2 OR 3 WITH FOOTWAY (100mm kerb upstand)	A	19/08/19
202	FCB	NAC/202/FCB	STREET TYPE 3 OR 4 WITH FOOTWAY (30mm kerb upstand)	A	19/08/19
203	DM4	NAC/203/DM4	STREET TYPE 4 WITH DEMARCATION ZONE	A	19/08/19
204	SC4	NAC/204/SC4	STREET TYPE 4 WITH SERVICE STRIP (50mm kerb upstand)	B	01/08/23
205	DW2	NAC/205/DW2	STREET TYPE 1, 2 OR 3 AT DRIVEWAY/ACCESS	C	01/08/23
206	DW3	NAC/206/DW3	STREET TYPE 4 AT DRIVEWAY/ACCESS	C	01/08/23
207	SNA1	NAC/207/SNA1	STREET TYPE 1, 2 OR 3 - NO ADJACENT ADOPTABLE ASSET (100mm kerb upstand)	A	19/08/19
208	SNA2	NAC/208/SNA2	STREET TYPE 3 or 4 - NO ADJACENT ADOPTABLE ASSET (50mm kerb upstand)	A	19/08/19
209	SFT	NAC/209/SFT	TYPICAL STREET WITH GULLY AND ADJACENT FILTER TRENCH	B	09/06/21
210	RFP	NAC/210/RFP	TYPICAL FOOTPATH WITH FILTER TRENCH	A	20/08/19
211	OVR	NAC/211/OVR	BLOCK PAVED OVERRUN CONSTRUCTION DETAIL	A	20/08/19
212	TRCS	NAC/212/TRCS	TRANSITION FEATURE TO A TYPE 3 OR 4 STREET	A	20/08/19
213	PAR	NAC/213/PAR	STANDARD FOOTWAY/OFF STREET PARKING BAYS CONSTRUCTION	A	20/08/19
<b>Utilities and Drainage</b>					
301	SER	NAC/301/SER	RECOMMENDED POSITIONING OF UTILITY APPARATUS IN A 2 METRE FOOTWAY	A	20/08/19
302	GUL	NAC/302/GUL	PRECAST CONCRETE TRAPPED STREET GULLY 450 mm NOMINAL BORE	A	20/08/19
303	MH1	NAC/303/MH1	TYPE B MANHOLE - MAXIMUM DEPTH 3 METRES (to be used within carriageway)	A	20/08/19
304	MH2	NAC/304/MH2	TYPE A MANHOLE - DEPTH 3 TO 6 METRES (to be used within carriageway)	A	20/08/19
305	CTP	NAC/305/CTP	CATCHPIT (to be used outwith carriageway)	A	20/08/19
306	ROD	NAC/306/ROD	RODDING EYE DETAIL	A	20/08/19
307	CPD	NAC/307/CPD	CARRIER PIPE DETAIL - PIPE BEDDING DETAIL	A	20/08/19
308	FLT1	NAC/308/FLT1	FILTER TRENCH CONSTRUCTION - SECTION	A	20/08/19
309	FLT2	NAC/309/FLT2	FILTER TRENCH CONSTRUCTION - PLAN	B	09/06/21
310	HCH	NAC/310/HCH	HYDROBRAKE CHAMBER	A	20/08/19
311	PS	NAC/311/PS	TYPICAL SECTION THROUGH POND MARGIN	A	21/08/19
312	PB	NAC/312/PB	TYPICAL SECTION THROUGH BASIN	A	21/08/19
313	PI	NAC/313/PI	DETENTION POND INLET HEADWALL DETAIL	A	21/08/19
314	PO	NAC/314/PO	DETENTION POND OUTLET HEADWALL DETAIL	A	21/08/19
315	PSG	NAC/315/PSG	DETENTION POND OUTFALL SAFETY GRILLE DETAIL	A	21/08/19
316	PPF	NAC/316/PPF	DETENTION POND/BASIN PERIMETER FENCE DETAIL	A	21/08/19
317	SWP	NAC/317/SWP	STANDARD WET SWALE/CARRIAGEWAY CONSTRUCTION	A	21/08/19
318	SWS	NAC/318/SWS	STANDARD WET SWALE/CARRIAGEWAY CONSTRUCTION	A	21/08/19
319	SDP	NAC/319/SDP	STANDARD DRY SWALE/CARRIAGEWAY CONSTRUCTION	A	21/08/19
320	SDS	NAC/320/SDS	STANDARD DRY SWALE/CARRIAGEWAY CONSTRUCTION	A	21/08/19
<b>Footway</b>					
401	TPS	NAC/401/TPS	TACTILE PAVING AT SIGNALS	A	21/08/19
402	TPC	NAC/402/TPC	TACTILE PAVING AT PEDESTRIAN	A	21/08/19

			CROSSING POINTS		
403	BS	NAC/403/BS	STANDARD BUS STOP CONSTRUCTION	A	21/08/19
404	DW1	NAC/404/DW1	STANDARD PRIVATE DRIVEWAY ACCESS (FOOTWAY)	B	25/02/20
405	SMA	NAC/405/SMA	SINGLE MINOR COMMERCIAL ACCESS, HOUSING COURT OR CAR PARK UP TO 50 SPACES	A	21/08/19
406	MCA	NAC/406/MCA	MINOR COMMERCIAL ACCESS OR CAR PARK OVER 50 SPACES	A	21/08/19
407	MAC	NAC/407/MAC	MAJOR COMMERCIAL ACCESS	A	21/08/19
408	DWD	NAC/408/DWD	MINIMUM DRIVEWAY DIMENSIONS	A	21/08/19
409	PCR	NAC/409/PCR	DROPPED KERB DETAIL AT DESIGNATED PEDESTRIAN CROSSING	B	10/01/20
410	DW4	NAC/410/DW4	STANDARD PRIVATE DRIVEWAY ACCESS (SERVICE STRIP)	B	23/09/20
<b>Miscellaneous</b>					
501	CAP	NAC/501/CAP	CAPPING LAYER REQUIREMENTS: SUBJECT TO FROST SUSCEPTIBILITY	A	21/08/19
502	BOL	NAC/502/BOL	BOLLARD DETAIL	A	21/08/19
503	TRE	NAC/503/TRE	TREE PIT DETAIL WITH CONTAINMENT	A	21/08/19
504	SCJ	NAC/504/SCJ	STEPPED CARRIAGEWAY JOINT	A	21/08/19
505	POS	NAC/505/POS	SIGNPOST FOUNDATION DETAIL	A	21/08/19
506	SNP	NAC/506/SNP	STREET NAMEPLATE DETAIL	A	21/08/19

## NOTES

1. All dimensions in millimetres.
2. For construction works in Arran HRA should be substituted for the following:  
HRA 30/14 to AC 10 close surf 100/150  
HRA 15/10 to AC 6 close surf 100/150

Carriageway Construction					
Road Type	Sub-Base	Base Course	Binder Course	Surface Course	
1	Connector Streets	300mm Granular Sub-base Type 1 (cl 803)	140mm Dense Base Course Asphalt Concrete Recipe Mixture (cl 906) (AC 32 Dense Base 100/150 rec)	60mm Dense Binder Course Asphalt Concrete Recipe Mixture (cl 906) (AC 20 Dense Bin 100/150 rec)	40mm Hot Rolled Asphalt Surface Course (Recipe Mixture) (cl 910) (HRA 30/14 F surf 40/60) Black 14/20mm Coated Chipping 40/60 PSV 60 (cl 915)
2	Local Residential Streets	300mm Granular Sub-base Type 1 (cl 803)	100mm Dense Base Course Asphalt Concrete Recipe Mixture (cl 906) (AC 32 Dense Base 100/150 rec)	60mm Dense Binder Course Asphalt Concrete Recipe Mixture (cl 906) (AC 20 Dense Bin 100/150 rec)	40mm Hot Rolled Asphalt Surface Course (Recipe Mixture) (cl 910) (HRA 30/14 F surf 40/60) Black 14/20mm Coated Chipping 40/60 PSV 60 (cl 915)
3	Shared Space Streets	300mm Granular Sub-base Type 1 (cl 803)	80mm Dense Base Course Asphalt Concrete Recipe Mixture (cl 906) (AC 32 Dense Base 100/150 rec)	50mm Dense Binder Course Asphalt Concrete Recipe Mixture (cl 906) (AC 20 Dense Bin 100/150 rec)	40mm Hot Rolled Asphalt Surface Course (Recipe Mixture) (cl 910) (HRA 30/14 F surf 40/60) Red 14/20mm Uncoated Chipping 40/60 PSV 60 (cl 915)
4	Level Surface Streets	300mm Granular Sub-base Type 1 (cl 803)	80mm Dense Base Course Asphalt Concrete Recipe Mixture (cl 906) (AC 32 Dense Base 100/150 rec)	50mm Dense Binder Course Asphalt Concrete Recipe Mixture (cl 906) (AC 20 Dense Bin 100/150 rec)	40mm Hot Rolled Asphalt Surface Course (Recipe Mixture) (cl 910) (HRA 30/14 F surf 40/60) Red 14/20mm Uncoated Chipping 40/60 PSV 60 (cl 915)
(a)			130mm Dense Binder Course Asphalt Concrete Recipe Mixture (cl 906) (AC 20 dense bin 100/150 rec)		
4	(b)	400mm Granular Sub-base Type 1 (cl 803)		50mm Bedding Layer of Sharp Sand or Crushed Rock (Appendix 7/1)	200 x 100 x 80mm Concrete Block Paving (cl 1043)

Footway/path, Cycle Track Construction			
Type	Sub-Base	Binder Course	Surface Course
Flexible Surfacing (Urban)	150mm Granular Sub-base Type 1 (cl 803)	50mm Dense Binder Course Asphalt Concrete Recipe Mixture (cl 906) (AC 20 dense bin 100/150 rec)	30mm Hot Rolled Asphalt Surface Course Recipe Mixture (cl 910) (HRA 15/10 F surf 40/60) Prior To Compaction 6mm Or 10mm Limestone Chippings Shall Be Applied To The Surface At A Nominal Of 1 Kg/m <sup>2</sup>
Flexible Surfacing (Rural)	200mm Granular Sub-base Type 1 (cl 803) or recycled suitable material (eg planings)	40mm Close Graded Asphalt Concrete (cl 912) (AC 14 close surf 100/150)	25mm Hot Rolled Asphalt Surface Course Recipe Mixture (cl 910) (HRA 15/10 F surf 40/60) Prior To Compaction 6mm Or 10mm Limestone Chippings Shall Be Applied To The Surface At A Nominal Of 1 Kg/m <sup>2</sup>  or subject to the agreement of NAC  25mm Close Graded Asphalt Concrete Surface Course (cl 912) (AC 10 close surf 100/150)
		Combined 50mm Close Graded Asphalt Concrete Surface course (cl 912) (AC 10 close surf 100/150)	
Block Paving or Paviers	150mm Granular Sub-base Type 1 (cl 803)	40±10 mm Bedding Layer of Sharp Sand or Crushed Rock Fines (Appendix 11/1)	200 x 100 x 65mm thick Rectangular Concrete Block Paving (cl 11 07) or Concrete Pavers (cl 1107)

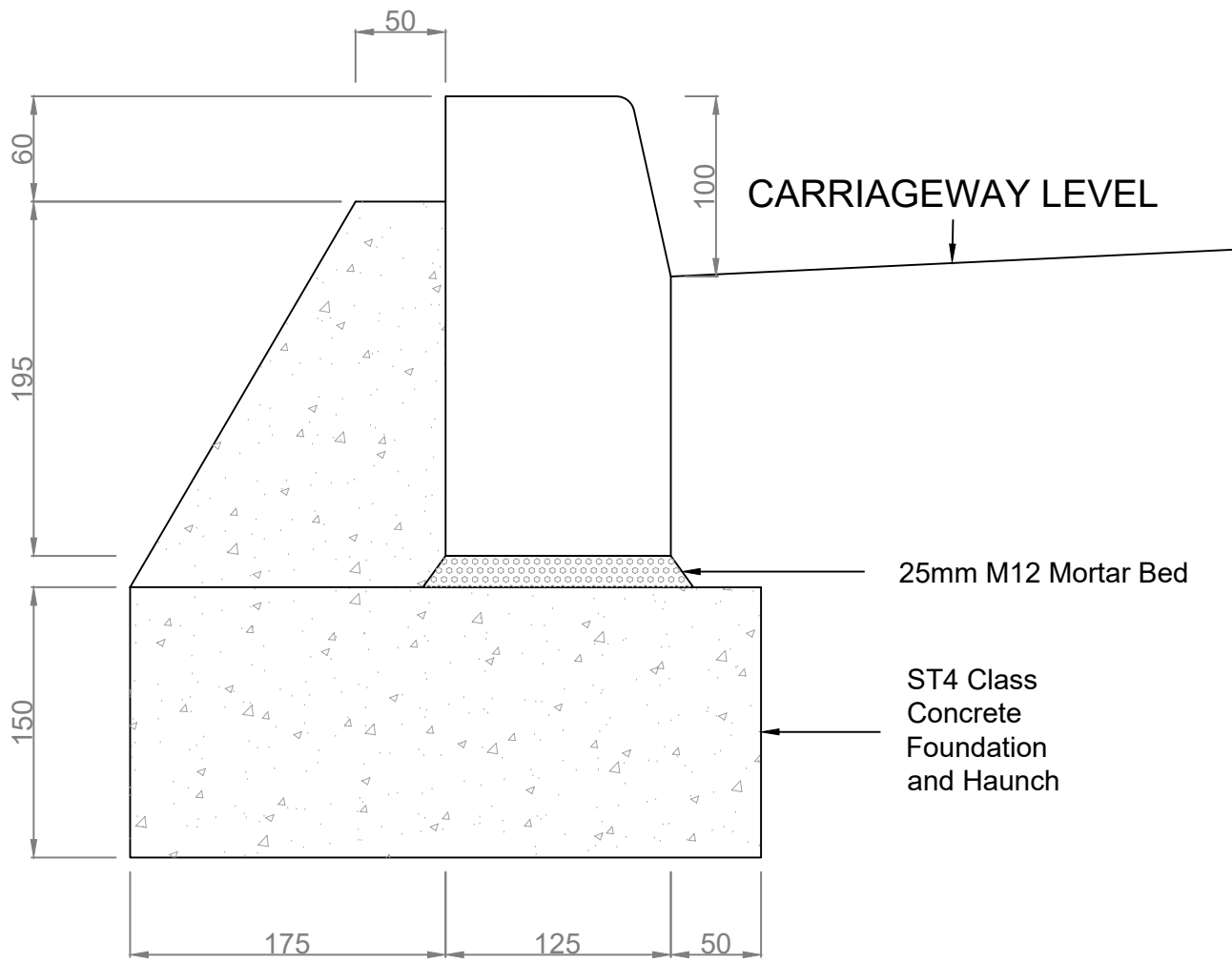

### NOTES

1. All dimensions in millimetres. (This drawing is not to scale)
2. Kerb details to comply with BS EN 1340.
3. Standard Kerb size 125mm x 255mm
4. Standard Kerb upstand 100mm or otherwise directed
5. Kerbs to be hydraulically pressed.
6. Kerb foundation and haunch to be concrete class ST4, 30 slump. Foundation slump may be reduced if kerbs laid wet.
7. Kerbs to be laid and bedded on a layer of M12 mortar not less than 10mm and not more than 40mm thick. Alternatively, kerbs may be laid directly on newly placed concrete foundation.
8. All kerbs to be abutted, except kerbs laid to a radius of less than 40m, which shall be laid with an average gap of 6mm and pointed with M12 mortar.
9. For curves of radius 12m or less, kerbs of appropriate radius shall be used as per BS EN 1340.

(This drawing is not to scale)



## PRECAST CONCRETE KERB TYPES STANDARD 125x255mm HALF BATTER KERB (HB1)

COPYRIGHT NORTH AYRSHIRE COUNCIL 2019. USED WITH THE PERMISSION OF NORTH AYRSHIRE COUNCIL FOR DEVELOPMENTS WITHIN NORTH AYRSHIRE ONLY.

DRAWING NO	REV
NAC/101/HB1	A

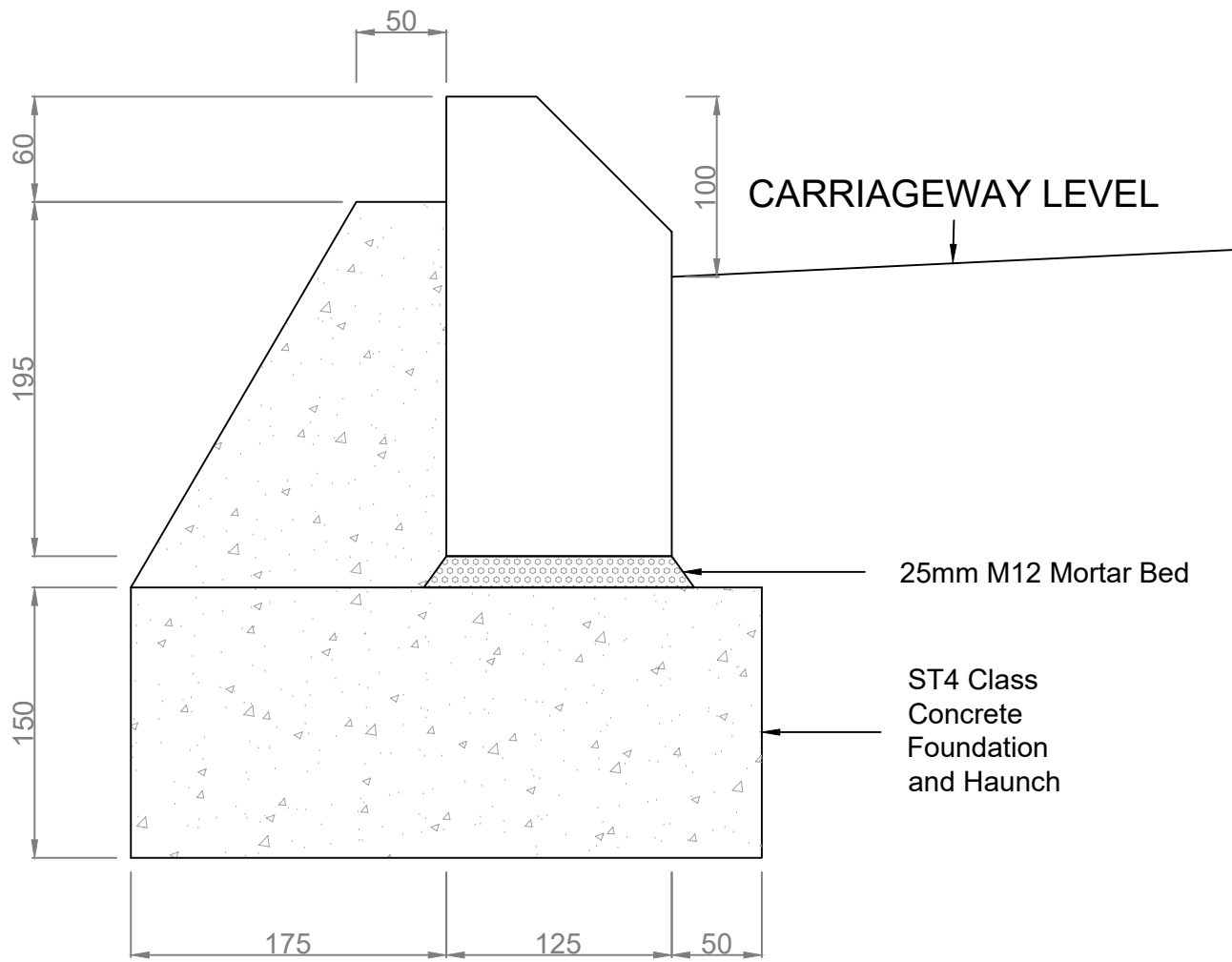

## NOTES

1. All dimensions in millimetres. (This drawing is not to scale)
2. Kerb details to comply with BS EN 1340.
3. Standard Kerb size 125mm x 255mm
4. Standard Kerb upstand 100mm or otherwise directed
5. Kerbs to be hydraulically pressed.
6. Kerb foundation and haunch to be concrete class ST4, 30 slump. Foundation slump may be reduced if kerbs laid wet.
7. Kerbs to be laid and bedded on a layer of M12 mortar not less than 10mm and not more than 40mm thick. Alternatively, kerbs may be laid directly on newly placed concrete foundation.
8. All kerbs to be abutted, except kerbs laid to a radius of less than 40m, which shall be laid with an average gap of 6mm and pointed with M12 mortar.
9. For curves of radius 12m or less, kerbs of appropriate radius shall be used as per BS EN 1340.

(This drawing is not to scale)



# PRECAST CONCRETE KERB TYPES

## STANDARD 125x255mm SPLAYED KERB (SP1)

COPYRIGHT NORTH AYRSHIRE COUNCIL 2019. USED WITH THE PERMISSION OF NORTH AYRSHIRE COUNCIL FOR DEVELOPMENTS WITHIN NORTH AYRSHIRE ONLY.

DRAWING NO	REV
NAC/102/SP1	A

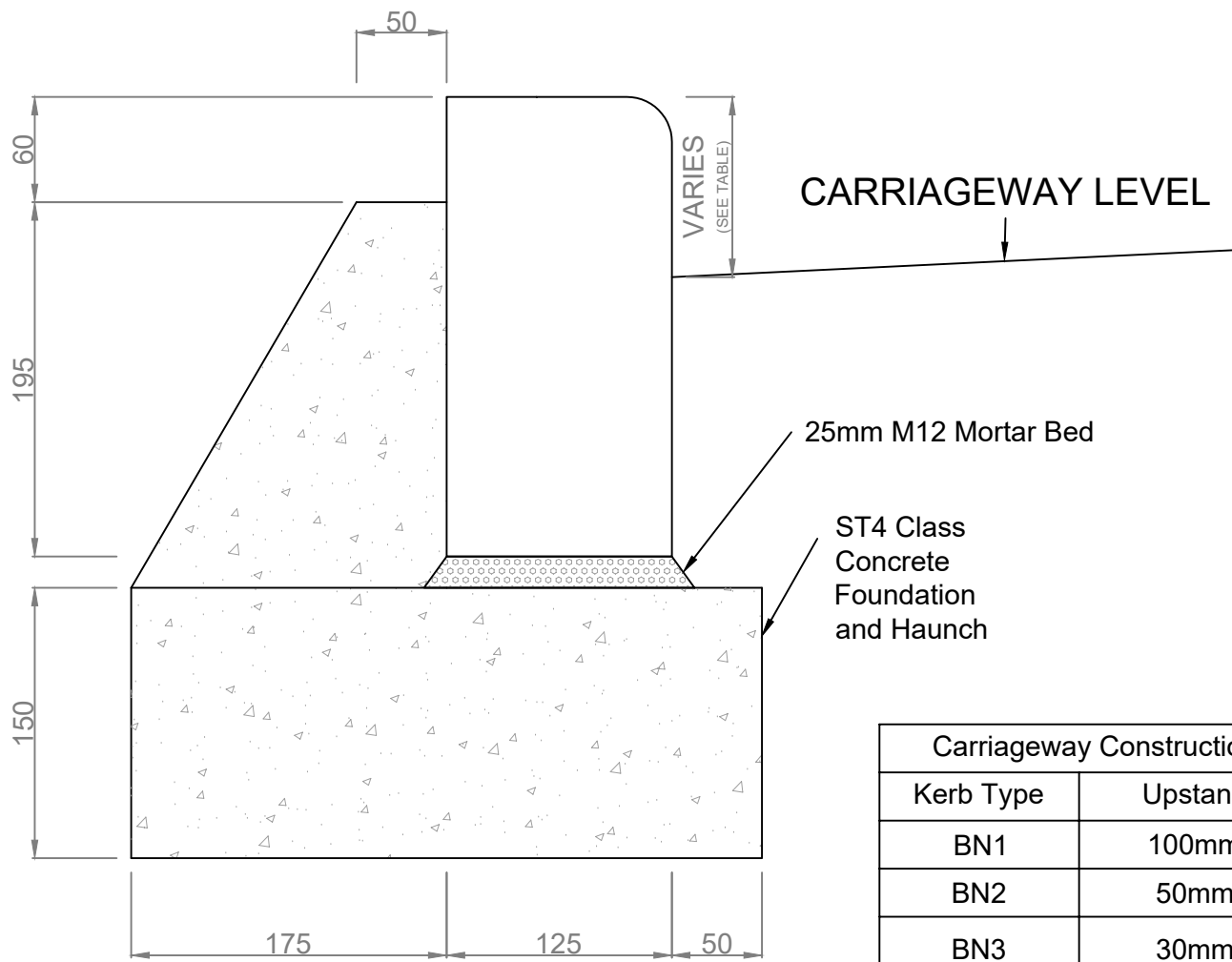

CARRIAGEWAY LEVEL

25mm M12 Mortar Bed

ST4 Class Concrete Foundation and Haunch

Carriageway Construction	
Kerb Type	Upstand
BN1	100mm
BN2	50mm
BN3	30mm
BN4	20mm
BN5	See NAC/104/BN5

**NOTES**

1. All dimensions in millimetres. (This drawing is not to scale)
2. Kerb details to comply with BS EN 1340.
3. Standard Kerb size 125mm x 255mm
4. Kerb upstand to be noted using Type Reference from the table shown
5. Kerbs to be hydraulically pressed.
6. Kerb foundation and haunch to be concrete class ST4, 30 slump. Foundation slump may be reduced if kerbs laid wet.
7. Kerbs to be laid and bedded on a layer of M12 mortar not less than 10mm and not more than 40mm thick. Alternatively, kerbs may be laid directly on newly placed concrete foundation.
8. All kerbs to be abutted, except kerbs laid to a radius of less than 40m, which shall be laid with an average gap of 6mm and pointed with M12 mortar.
9. For curves of radius 12m or less, kerbs of appropriate radius shall be used as per BS EN 1340.

(This drawing is not to scale)



**PRECAST CONCRETE KERB TYPES**  
**STANDARD 125x255mm BULLNOSED KERB (Various Upstand)**

COPYRIGHT NORTH AYRSHIRE COUNCIL 2019. USED WITH THE PERMISSION OF NORTH AYRSHIRE COUNCIL FOR DEVELOPMENTS WITHIN NORTH AYRSHIRE ONLY.

DRAWING NO	REV
NAC/103/BNK	A

## NOTES

1. All dimensions in millimetres. (This drawing is not to scale)
2. Kerb details to comply with BS EN 1340.
3. Standard Kerb size 125mm x 150mm
4. Standard Kerb upstand 0-6mm at Pedestrian Crossing
5. Kerbs to be hydraulically pressed.
6. Kerb foundation and haunch to be concrete class ST4, 30 slump. Foundation slump may be reduced if kerbs laid wet.
7. Kerbs to be laid and bedded on a layer of M12 mortar not less than 10mm and not more than 40mm thick. Alternatively, kerbs may be laid directly on newly placed concrete foundation.
8. All kerbs to be abutted, except kerbs laid to a radius of less than 40m, which shall be laid with an average gap of 6mm and pointed with M12 mortar.
9. For curves of radius 12m or less, kerbs of appropriate radius shall be used as per BS EN 1340.

(This drawing is not to scale)

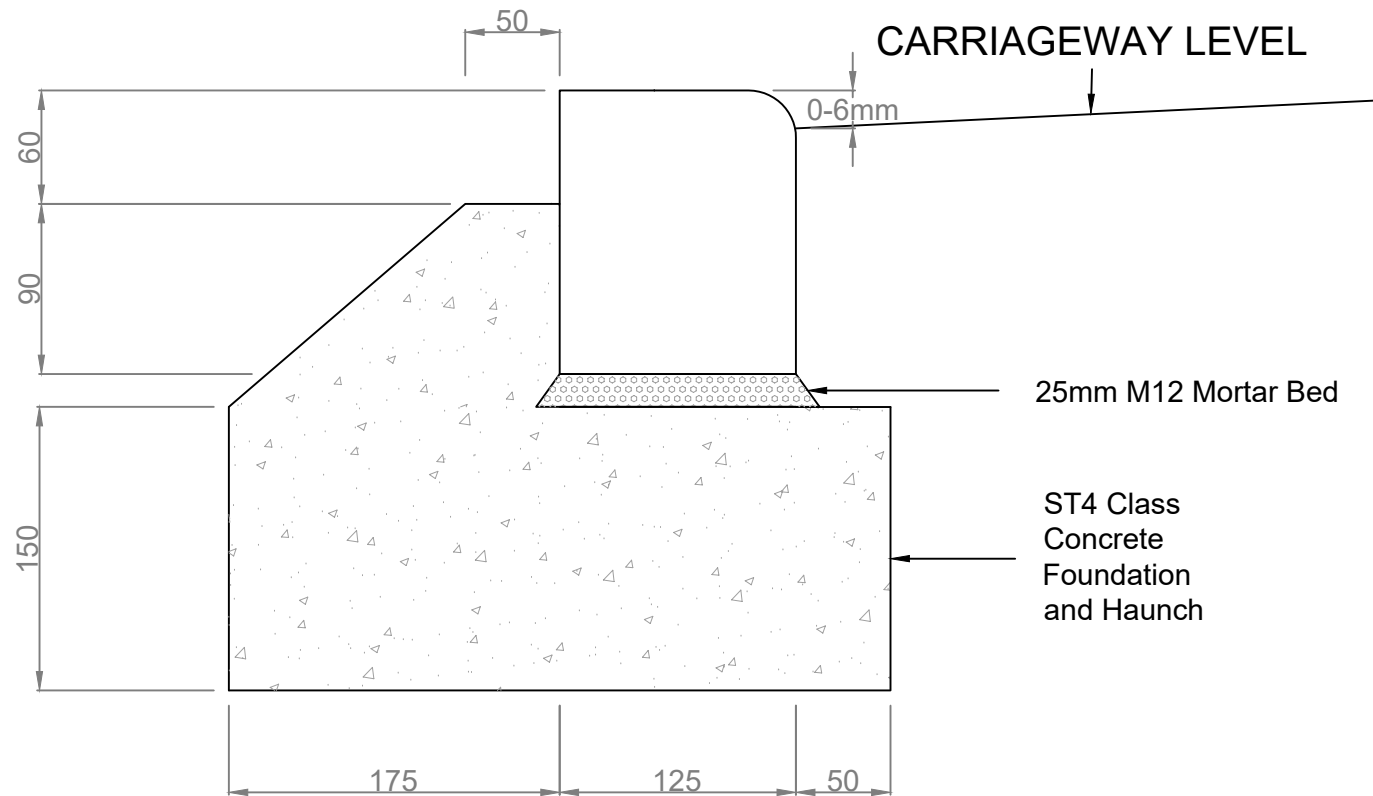

## PRECAST CONCRETE KERB TYPES STANDARD 125x150mm BULLNOSED KERB (BN5)



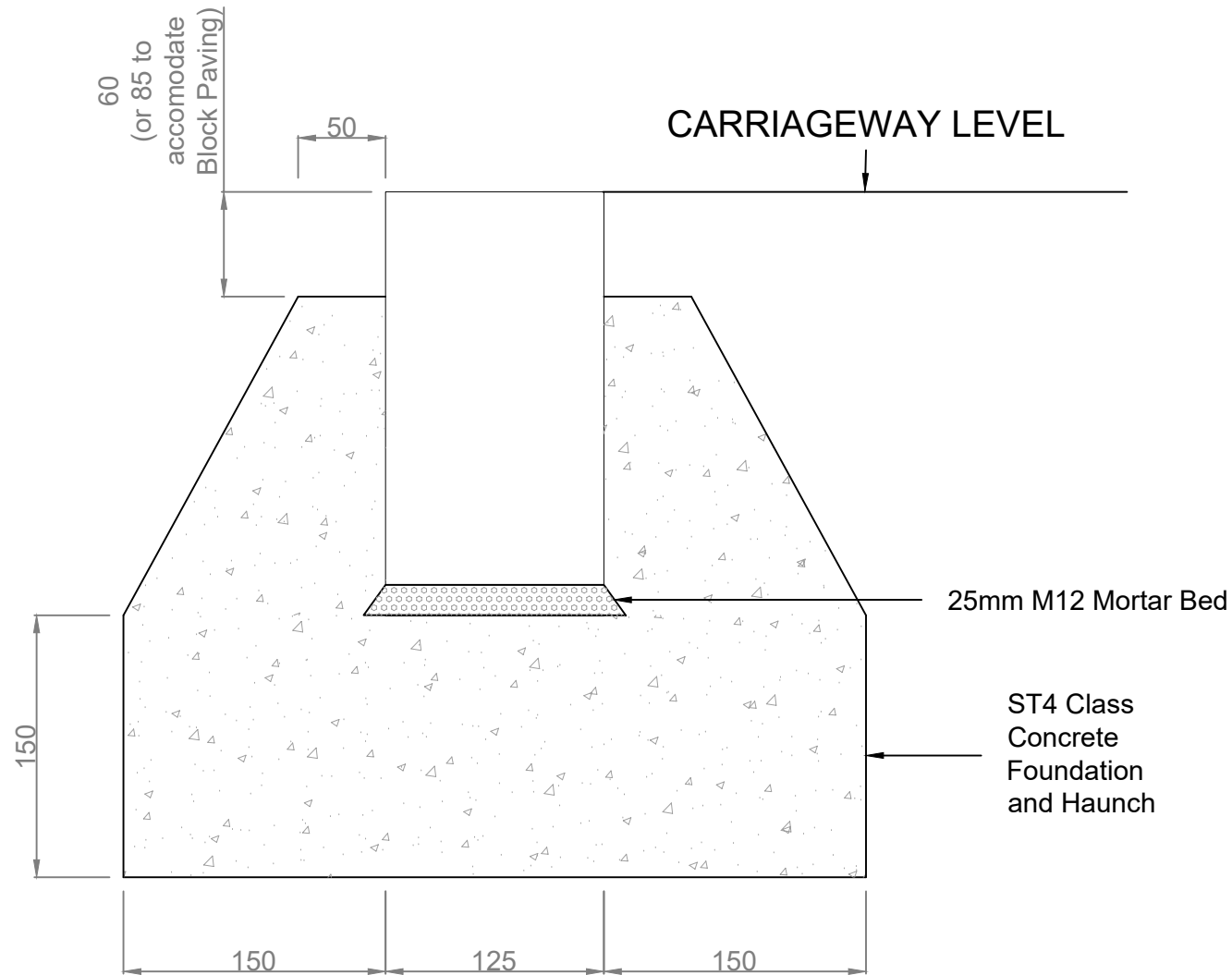

## NOTES

1. All dimensions in millimetres. (This drawing is not to scale)
2. Kerb details to comply with BS EN 1340.
3. Standard Kerb size 125mm x 225mm
4. Standard Kerb upstand 0mm or otherwise directed
5. Kerbs to be hydraulically pressed.
6. Kerb foundation and haunch to be concrete class ST4, 30 slump. Foundation slump may be reduced if kerbs laid wet.
7. Kerbs to be laid and bedded on a layer of M12 mortar not less than 10mm and not more than 40mm thick. Alternatively, kerbs may be laid directly on newly placed concrete foundation.
8. All kerbs to be abutted, except kerbs laid to a radius of less than 40m, which shall be laid with an average gap of 6mm and pointed with M12 mortar.
9. For curves of radius 12m or less, kerbs of appropriate radius shall be used as per BS EN 1340.

(This drawing is not to scale)

## NOTES

1. All dimensions in millimetres. (This drawing is not to scale)
2. Kerb details to comply with BS EN 1340.
3. Standard Edging Kerb size 50mm x 150mm
4. Standard Kerb upstand 50mm or otherwise directed
5. Kerbs to be hydraulically pressed.
6. Kerb foundation and haunch to be concrete class ST4, 30 slump. Foundation slump may be reduced if kerbs laid wet.
7. Kerbs to be laid and bedded on a layer of M12 mortar not less than 10mm and not more than 40mm thick. Alternatively, kerbs may be laid directly on newly placed concrete foundation.
8. All kerbs to be abutted, except kerbs laid to a radius of less than 40m, which shall be laid with an average gap of 6mm and pointed with M12 mortar.
9. For curves of radius 12m or less, kerbs of appropriate radius shall be used as per BS EN 1340.

(This drawing is not to scale)

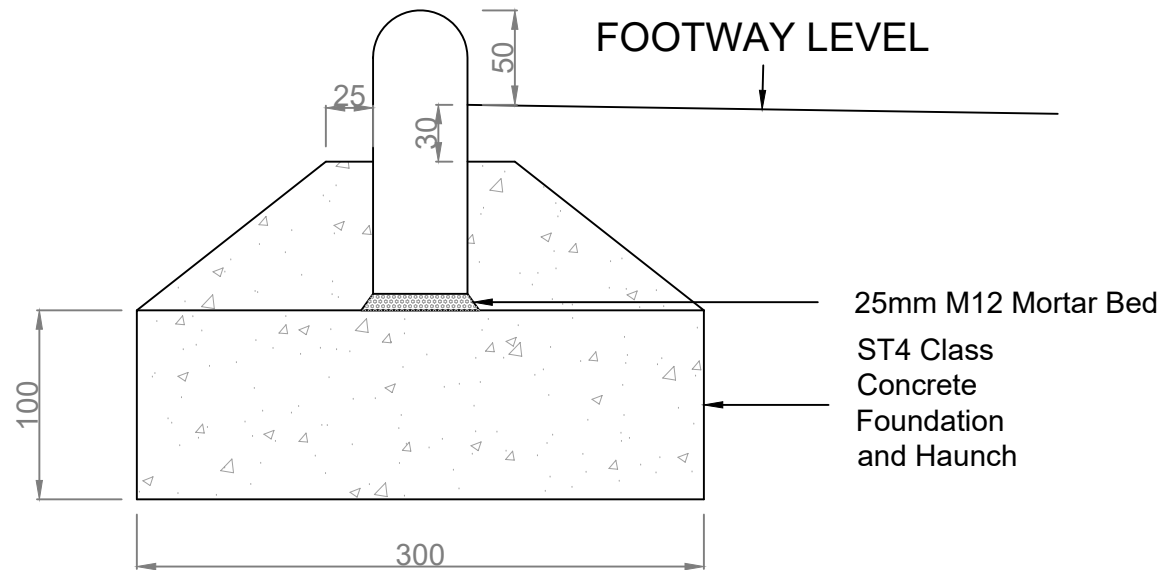

## NOTES

1. All dimensions in millimetres. (This drawing is not to scale)
2. Kerb details to comply with BS EN 1340.
3. Standard Edging Kerb size 50mm x 150mm
4. Standard Kerb upstand 0mm or otherwise directed
5. Kerbs to be hydraulically pressed.
6. Kerb foundation and haunch to be concrete class ST4, 30 slump. Foundation slump may be reduced if kerbs laid wet.
7. Kerbs to be laid and bedded on a layer of M12 mortar not less than 10mm and not more than 40mm thick. Alternatively, kerbs may be laid directly on newly placed concrete foundation.
8. All kerbs to be abutted, except kerbs laid to a radius of less than 40m, which shall be laid with an average gap of 6mm and pointed with M12 mortar.
9. For curves of radius 12m or less, kerbs of appropriate radius shall be used as per BS EN 1340.

(This drawing is not to scale)

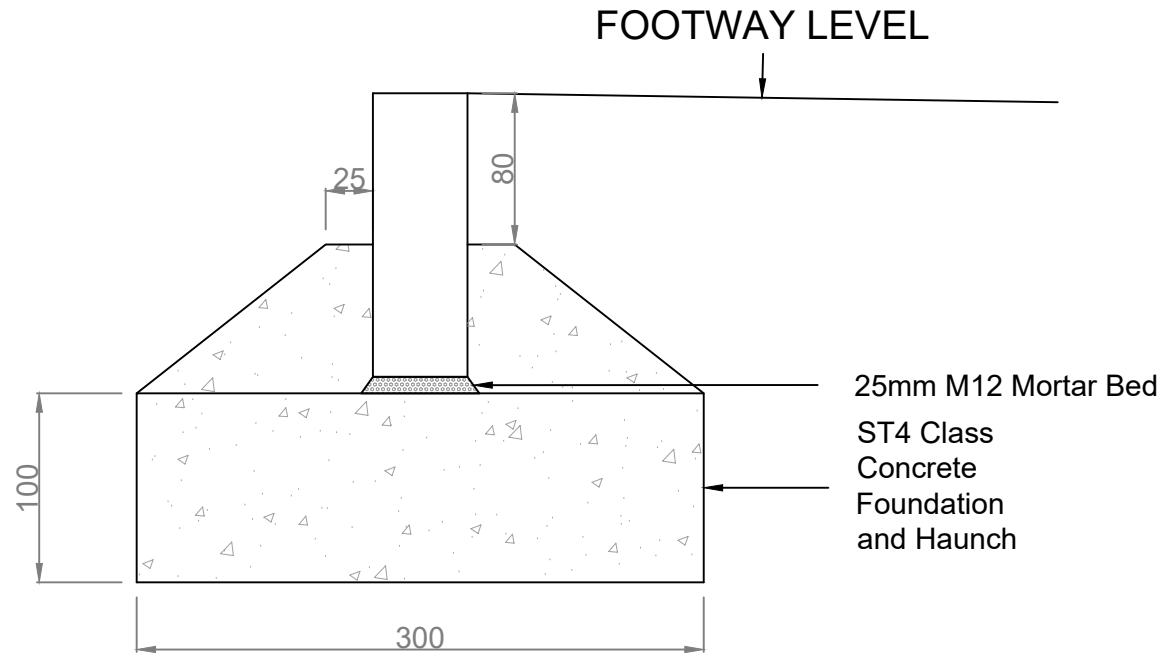

## PRECAST CONCRETE KERB TYPES STANDARD 50x150mm FLAT TOP EDGING KERB (FT)

## NOTES



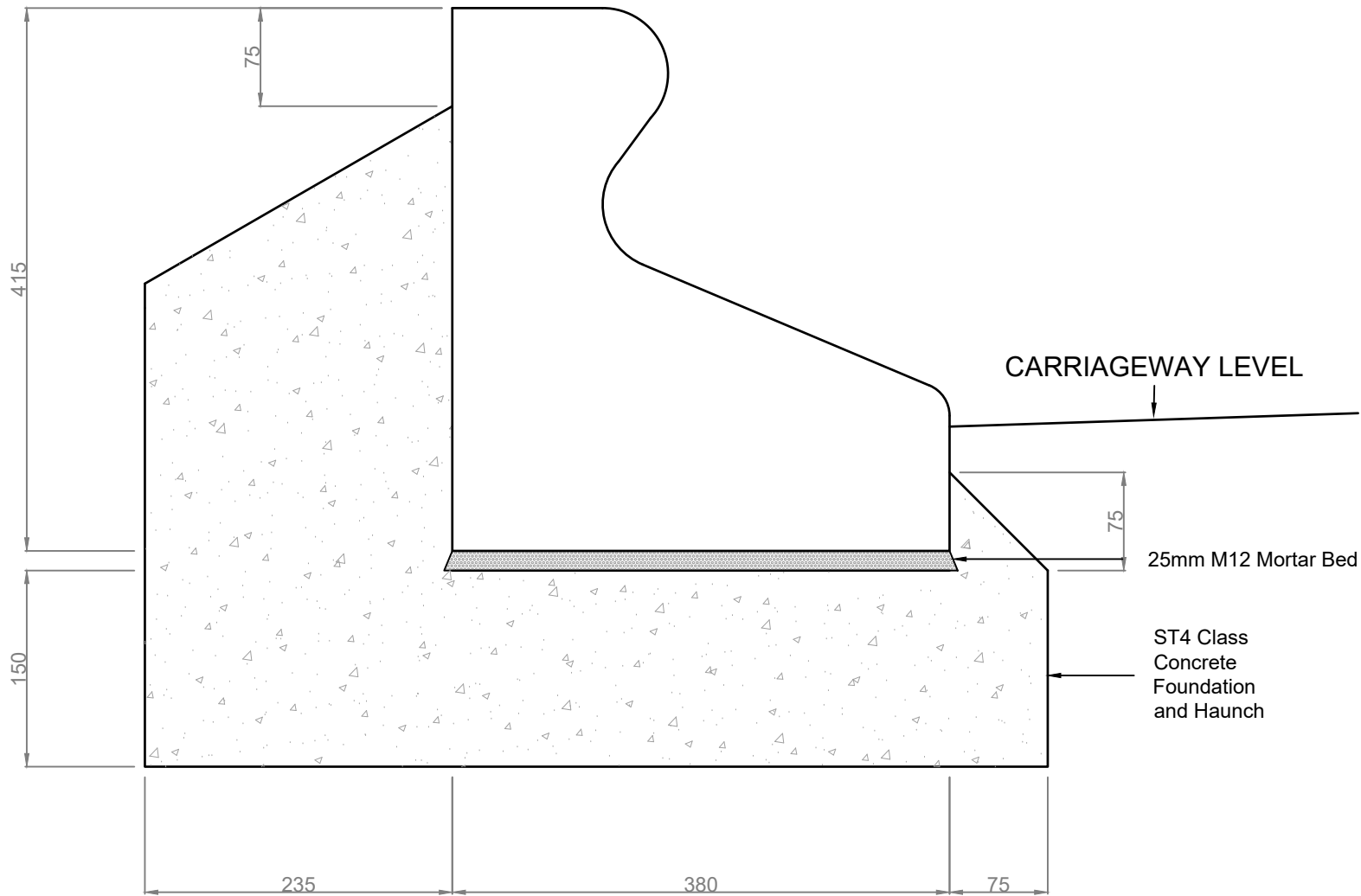

1. All dimensions in millimetres. (This drawing is not to scale)
2. Kerb details to comply with BS EN 1340.
3. Kerbs to be hydraulically pressed.
4. Kerb foundation and haunch to be concrete class ST4, 30 slump. Foundation slump may be reduced if kerbs laid wet.
5. Kerbs to be laid and bedded on a layer of M12 mortar not less than 10mm and not more than 40mm thick. Alternatively, kerbs may be laid directly on newly placed concrete foundation.
6. All kerbs to be abutted, except kerbs laid to a radius of less than 40m, which shall be laid with an average gap of 6mm and pointed with M12 mortar.
7. For curves of radius 12m or less, kerbs of appropriate radius shall be used as per BS EN 1340.

(This drawing is not to scale)

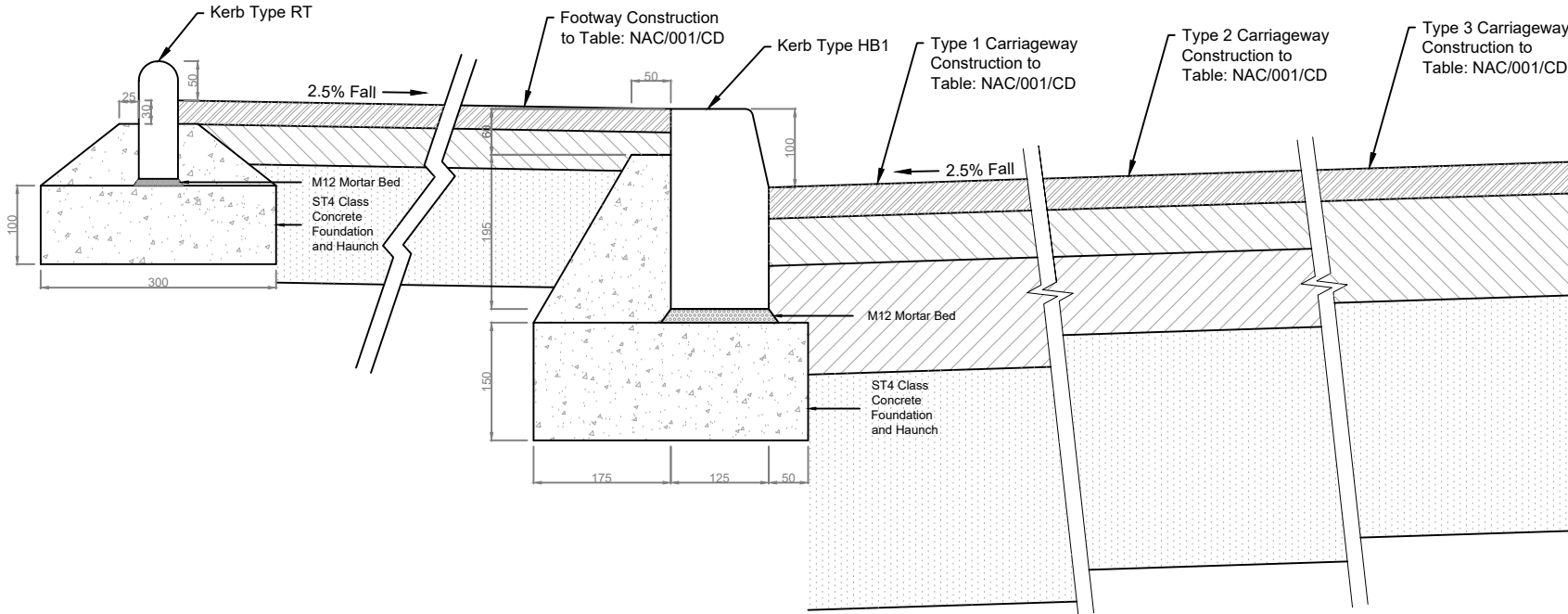

## PRECAST CONCRETE KERB TYPES STANDARD TRIEF KERB (TR)



-  SURFACE COURSE
-  BINDER COURSE
-  BASE COURSE
-  SUB-BASE





Carriageway Construction				
Road Type	Sub-Base	Base Course	Binder Course	Surface Course
1 Connector Streets	300mm Granular Sub-base Type 1 (cl 803)	140mm Dense Base Course Asphalt Concrete (Recipe Mixture (cl 906), (AC 32 dense base 100/150 rec)	60mm Dense Binder Course Asphalt Concrete (Recipe Mixture) (cl 906), (AC 20 dense bin 100/150 rec)	40mm Hot Rolled Asphalt Surface Course (Recipe Mixture) (cl 910), (HRA 30/14 F surf 40/60) with Black 14/20mm Coated Chipping 40/60 PSV 60 (cl 915)
2 Local Residential Streets	300mm Granular Sub-base Type 1 (cl 803)	100mm Dense Base Course Asphalt Concrete (Recipe Mixture (cl 906), (AC 32 dense base 100/150 rec)	60mm Dense Binder Course Asphalt Concrete (Recipe Mixture) (cl 906), (AC 20 dense bin 100/150 rec)	40mm Hot Rolled Asphalt Surface Course (Recipe Mixture) (cl 910), (HRA 30/14 F surf 40/60) with Black 14/20mm Coated Chipping 40/60 PSV 60 (cl 915)
3 Shared Space Streets	300mm Granular Sub-base Type 1 (cl 803)	80mm Dense Base Course Asphalt Concrete (Recipe Mixture (cl 906), (AC 32 dense base 100/150 rec)	50mm Dense Binder Course Asphalt Concrete (Recipe Mixture) (cl 906), (AC 20 dense bin 100/150 rec)	40mm Hot Rolled Asphalt Surface Course (Recipe Mixture) (cl 910), (HRA 30/14 F surf 40/60) with Red 14/20mm Uncoated Chipping 40/60 PSV 60 (cl 915)
		130mm Dense Binder Course Asphalt Concrete (Recipe Mixture) (cl 906), (AC 20 dense bin 100/150 rec)		

## NOTES

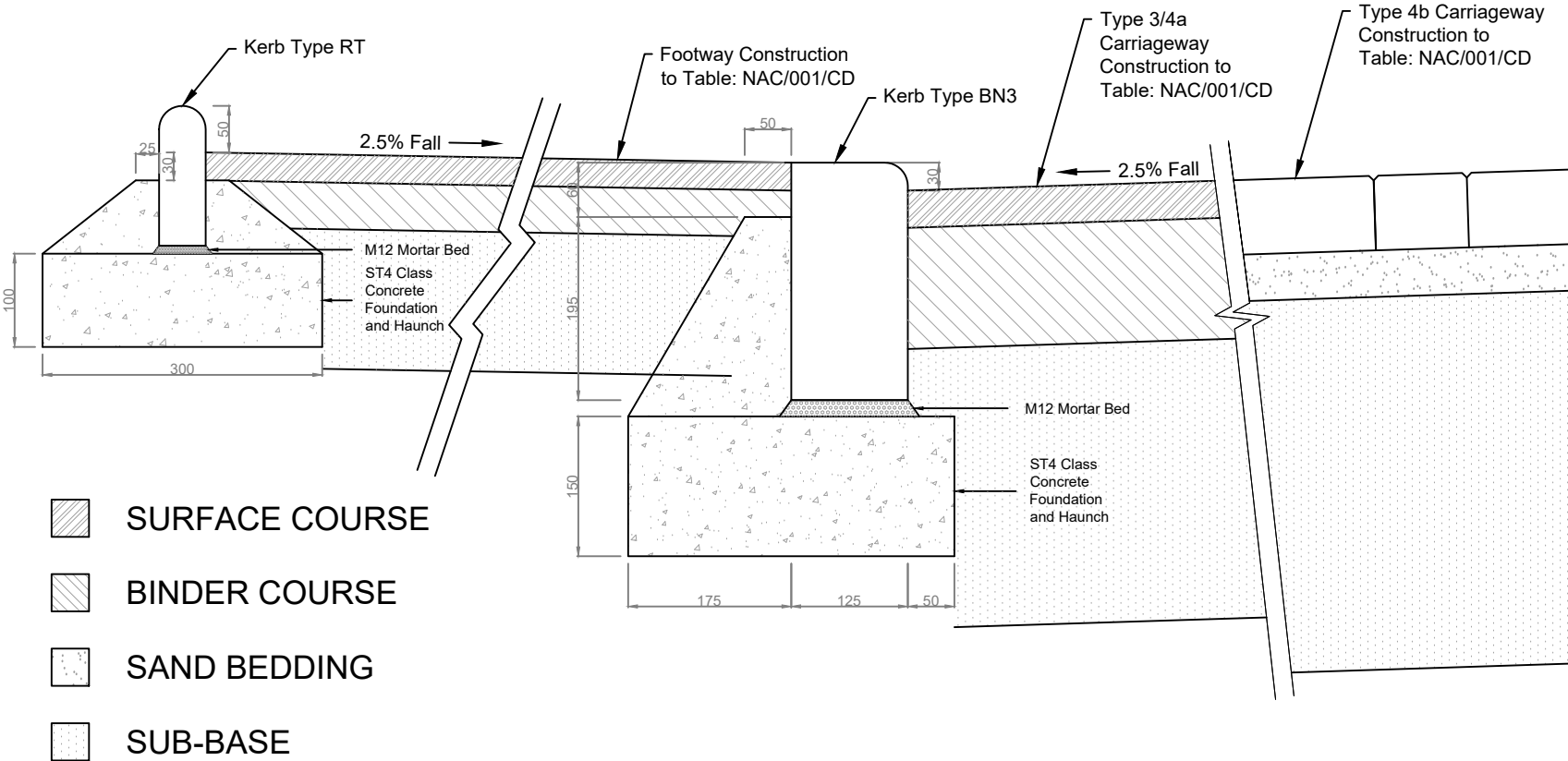
1. All dimensions in millimetres. (This drawing is not to scale)
2. New Kerbing details to comply with drawing as stated
3. Full Construction Information for Carriageway to Table NAC/001/CD
4. Full Construction Information for Footway to Table NAC/001/CD

(This drawing is not to scale)



-  SURFACE COURSE
-  BINDER COURSE
-  SAND BEDDING
-  SUB-BASE

### NOTES

1. All dimensions in millimetres. (This drawing is not to scale)
  2. New Kerbing details to comply with drawing as stated
  3. Full Construction Information for Carriageway to Table NAC/001/CD
  4. Full Construction Information for Footway to Table NAC/001/CD
- (This drawing is not to scale)

Carriageway Construction					
Road Type		Sub-Base	Base Course	Binder Course	Surface Course
3	Shared Space Streets	300mm Granular Sub-base Type 1 (cl 803)	80mm Dense Base Course Asphalt Concrete (Recipe Mixture (cl 906), (AC 32 dense base 100/150 rec)	50mm Dense Binder Course Asphalt Concrete (Recipe Mixture) (cl 906), (AC 20 dense bin 100/150 rec)	40mm Hot Rolled Asphalt Surface Course (Recipe Mixture) (cl 910), (HRA 30/14 F surf 40/60) with Red 14/20mm Uncoated Chipping 40/60 PSV 60 (cl 915)
			130mm Dense Binder Course Asphalt Concrete (Recipe Mixture) (cl 906), (AC 20 dense bin 100/150 rec)		
4 (a)	Level Surface Streets	300mm Granular Sub-base Type 1 (cl 803)	80mm Dense Base Course Asphalt Concrete (Recipe Mixture (cl 906), (AC 32 dense base 100/150 rec)	50mm Dense Binder Course Asphalt Concrete (Recipe Mixture) (cl 906), (AC 20 dense bin 100/150 rec)	40mm Hot Rolled Asphalt Surface Course (Recipe Mixture) (cl 910), (HRA 30/14 F surf 40/60) with Red 14/20mm Uncoated Chipping 40/60 PSV 60 (cl 915)
			130mm Dense Binder Course Asphalt Concrete (Recipe Mixture) (cl 906), (AC 20 dense bin 100/150 rec)		
4 (b)		400mm Granular Sub-base Type 1 (cl 803)		50mm Bedding Layer of Sharp Sand or Crushed Rock (Appendix 7/1)	200 x 100 x 80mm thick Concrete Rectangular Block Paving (cl 1043)



## STREET TYPE 3 OR 4 WITH FOOTWAY (30mm kerb upstand)

COPYRIGHT NORTH AYRSHIRE COUNCIL 2019. USED WITH THE PERMISSION OF NORTH AYRSHIRE COUNCIL FOR DEVELOPMENTS WITHIN NORTH AYRSHIRE ONLY.





DRAWING NO	REV
NAC/202/FCB	A

## NOTES

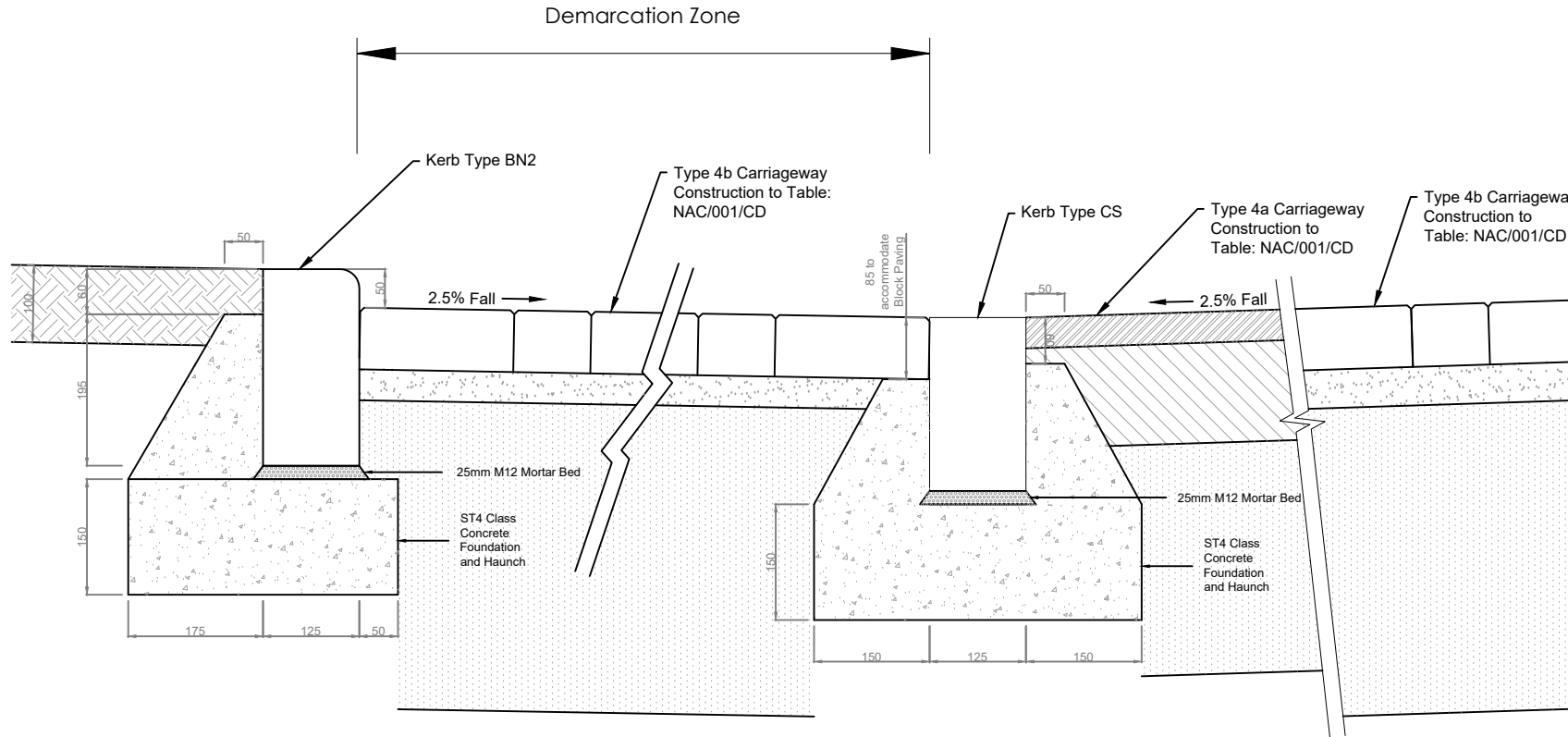
1. All dimensions in millimetres. (This drawing is not to scale)
2. New Kerbing details to comply with drawing as stated
3. Full Construction Information for Carriageway to Table NAC/001/CD
4. Full Construction Information for Footway to Table NAC/001/CD

(This drawing is not to scale)



-  SURFACE COURSE
-  BINDER COURSE
-  SAND BEDDING
-  SUB-BASE
-  TOP SOIL & GRASS SEED





Carriageway Construction				
Road Type	Sub-Base	Base Course	Binder Course	Surface Course
4 (a)	300mm Granular Sub-base Type 1 (cl 803)	80mm Dense Base Course Asphalt Concrete (Recipe Mixture (cl 906), (AC 32 dense base 100/150 rec)	50mm Dense Binder Course Asphalt Concrete (Recipe Mixture) (cl 906), (AC 20 dense bin 100/150 rec)	40mm Hot Rolled Asphalt Surface Course (Recipe Mixture) (cl 910), (HRA 30/14 F surf 40/60) with Red 14/20mm Uncoated Chipping 40/60 PSV 60 (cl 915)
		130mm Dense Binder Course Asphalt Concrete (Recipe Mixture) (cl 906), (AC 20 dense bin 100/150 rec)		
4 (b)	400mm Granular Sub-base Type 1 (cl 803)	50mm Bedding Layer of Sharp Sand or Crushed Rock (Appendix 7/1)		200 x 100 x 80mm thick Concrete Rectangular Block Paving (cl 1043)

## NOTES

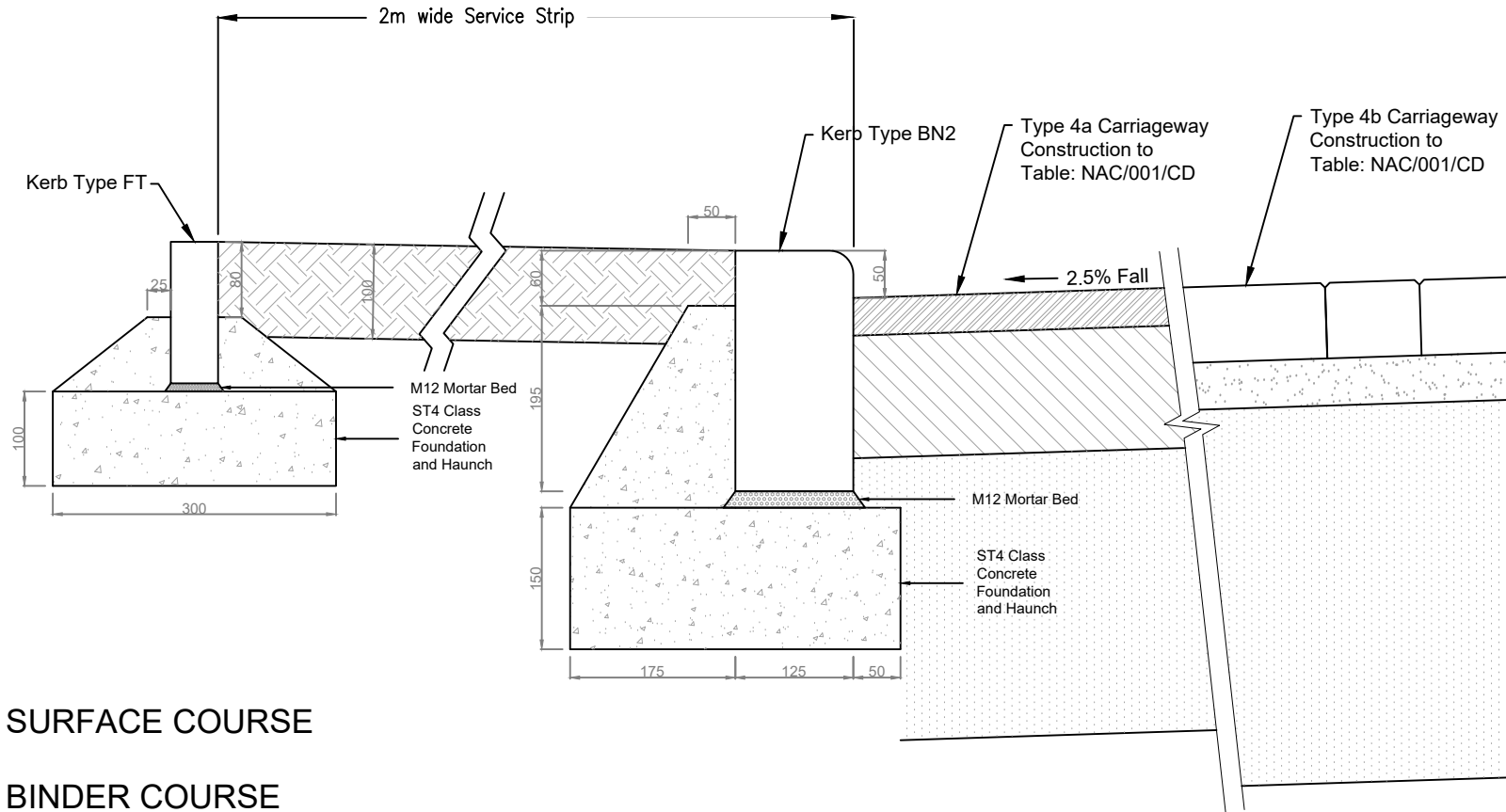
1. All dimensions in millimetres. (This drawing is not to scale)
2. New Kerbing details to comply with drawing as stated
3. Full Construction Information for Carriageway to Table NAC/001/CD

(This drawing is not to scale)



-  SURFACE COURSE
-  BINDER COURSE
-  SAND BEDDING
-  SUB-BASE
-  TOP SOIL & GRASS SEED

### Carriageway Construction

Road Type	Sub-Base	Base Course	Binder Course	Surface Course
4 (a)	300mm Granular Sub-base Type 1 (cl 803)	80mm Dense Base Course Asphalt Concrete (Recipe Mixture (cl 906), (AC 32 dense base 100/150 rec)	50mm Dense Binder Course Asphalt Concrete (Recipe Mixture) (cl 906), (AC 20 dense bin 100/150 rec)	40mm Hot Rolled Asphalt Surface Course (Recipe Mixture) (cl 910), (HRA 30/14 F surf 40/60) with Red 14/20mm Uncoated Chipping 40/60 PSV 60 (cl 915)
		130mm Dense Binder Course Asphalt Concrete (Recipe Mixture) (cl 906), (AC 20 dense bin 100/150 rec)		
4 (b)	400mm Granular Sub-base Type 1 (cl 803)	50mm Bedding Layer of Sharp Sand or Crushed Rock (Appendix 7/1)		200 x 100 x 80mm thick Concrete Rectangular Block Paving (cl 1043)





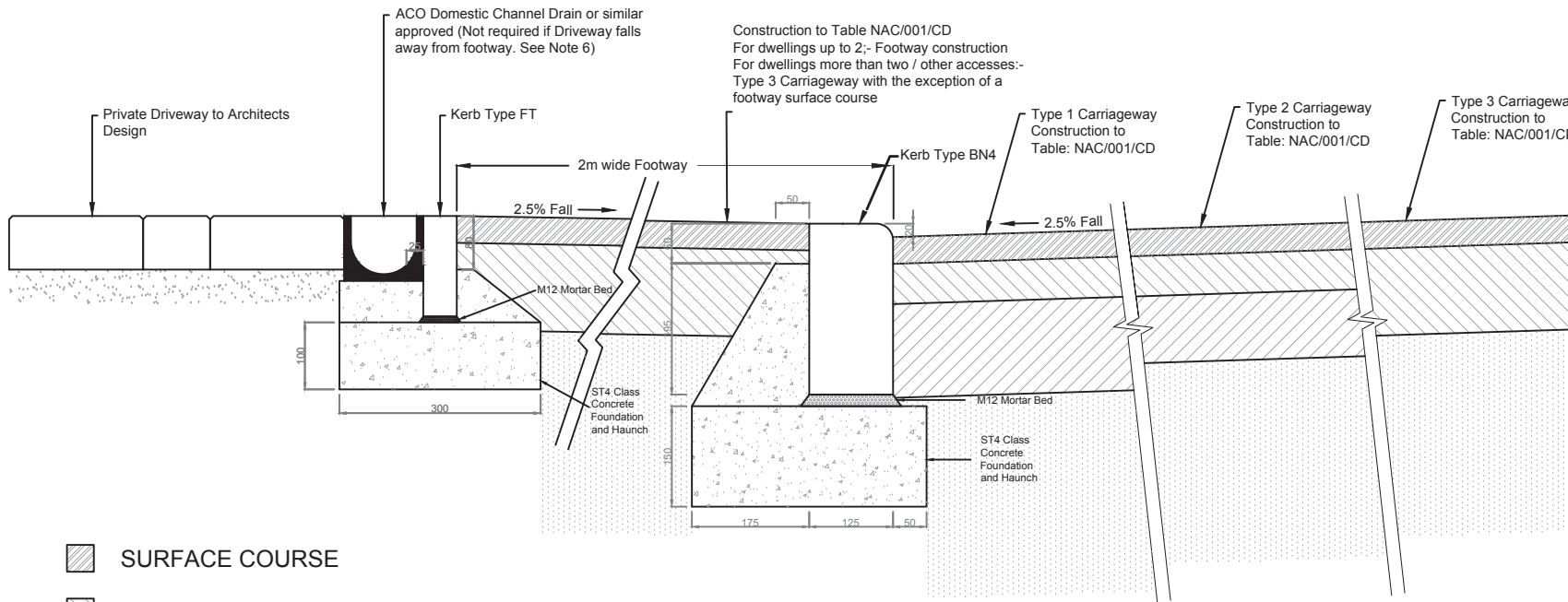

# NOTES

1. All dimensions in millimetres. (This drawing is not to scale)
2. This drawing should be read in conjunction with drawing NAC/404/DW1
3. New Kerbing details to comply with drawing as stated
4. Full Construction Information for Carriageway to Table NAC/001/CD
5. Full Construction Information for Footway to Table NAC/001/CD
6. Where the gradient of the Private Driveway slopes towards the Public Footway, a Drainage Channel as depicted must be installed. It is not required if the Private Driveway slopes into the private grounds.

(This drawing is not to scale)



-  SURFACE COURSE
-  BINDER COURSE
-  BASE COURSE
-  SUB-BASE





Carriageway Construction				
Road Type	Sub-Base	Base Course	Binder Course	Surface Course
1 Connector Streets	300mm Granular Sub-base Type 1 (cl 803)	140mm Dense Base Course Asphalt Concrete (Recipe Mixture (cl 906), (AC 32 dense base 100/150 rec)	60mm Dense Binder Course Asphalt Concrete (Recipe Mixture) (cl 906), (AC 20 dense bin 100/150 rec)	40mm Hot Rolled Asphalt Surface Course (Recipe Mixture) (cl 910), (HRA 30/14 F surf 40/60) with Black 14/20mm Coated Chipping 40/60 PSV 60 (cl 915)
2 Local Residential Streets	300mm Granular Sub-base Type 1 (cl 803)	100mm Dense Base Course Asphalt Concrete (Recipe Mixture (cl 906), (AC 32 dense base 100/150 rec)	60mm Dense Binder Course Asphalt Concrete (Recipe Mixture) (cl 906), (AC 20 dense bin 100/150 rec)	40mm Hot Rolled Asphalt Surface Course (Recipe Mixture) (cl 910), (HRA 30/14 F surf 40/60) with Black 14/20mm Coated Chipping 40/60 PSV 60 (cl 915)
3 Shared Space Streets	300mm Granular Sub-base Type 1 (cl 803)	80mm Dense Base Course Asphalt Concrete (Recipe Mixture (cl 906), (AC 32 dense base 100/150 rec)	50mm Dense Binder Course Asphalt Concrete (Recipe Mixture) (cl 906), (AC 20 dense bin 100/150 rec)	40mm Hot Rolled Asphalt Surface Course (Recipe Mixture) (cl 910), (HRA 30/14 F surf 40/60) with Red 14/20mm Uncoated Chipping 40/60 PSV 60 (cl 915)
		130mm Dense Binder Course Asphalt Concrete (Recipe Mixture) (cl 906), (AC 20 dense bin 100/150 rec)		

# NOTES

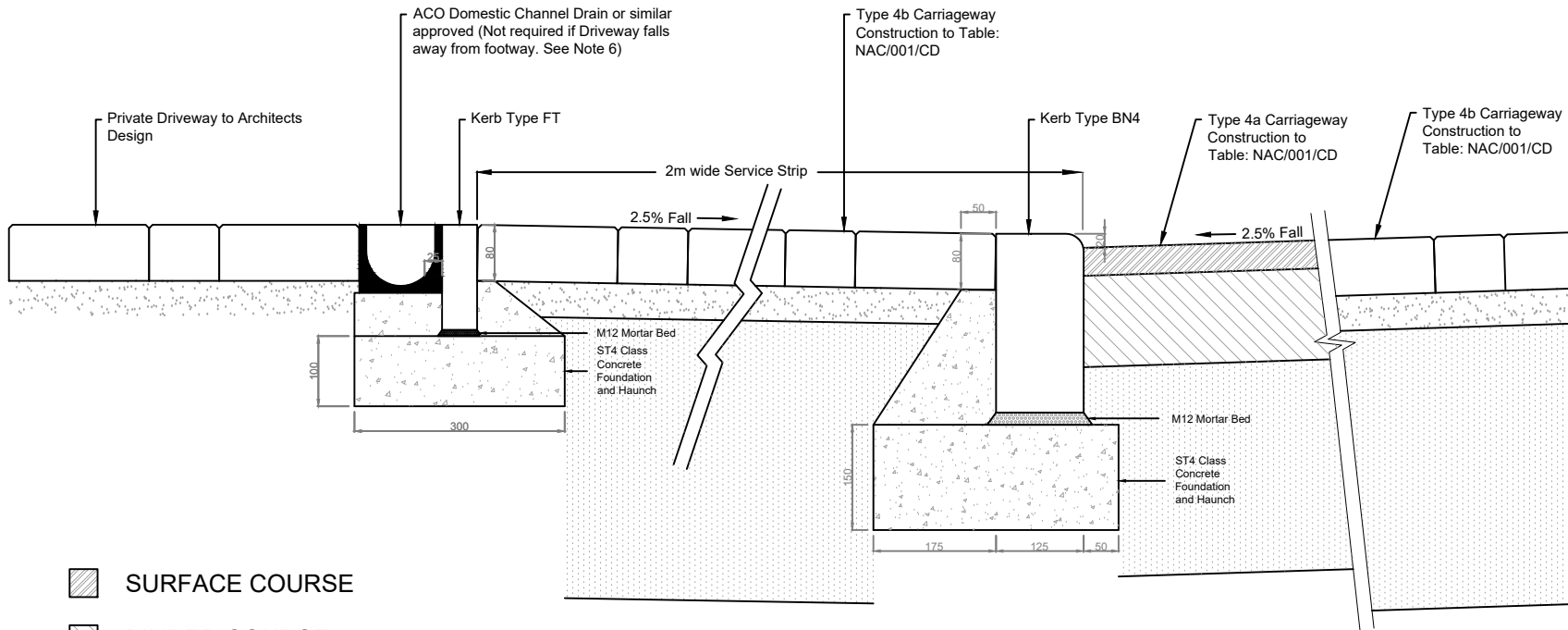
1. All dimensions in millimetres. (This drawing is not to scale)
2. This drawing should be read in conjunction with drawing NAC/410/DW4
3. New Kerbing details to comply with drawing as stated
4. Full Construction Information for Carriageway to Table NAC/001/CD
5. Full Construction Information for Footway to Table NAC/001/CD
6. Where the gradient of the Private Driveway slopes towards the Public Footway, a Drainage Channel as depicted must be installed. It is not required if the Private Driveway slopes into the private grounds.

(This drawing is not to scale)



-  SURFACE COURSE
-  BINDER COURSE
-  SAND BEDDING
-  SUB-BASE



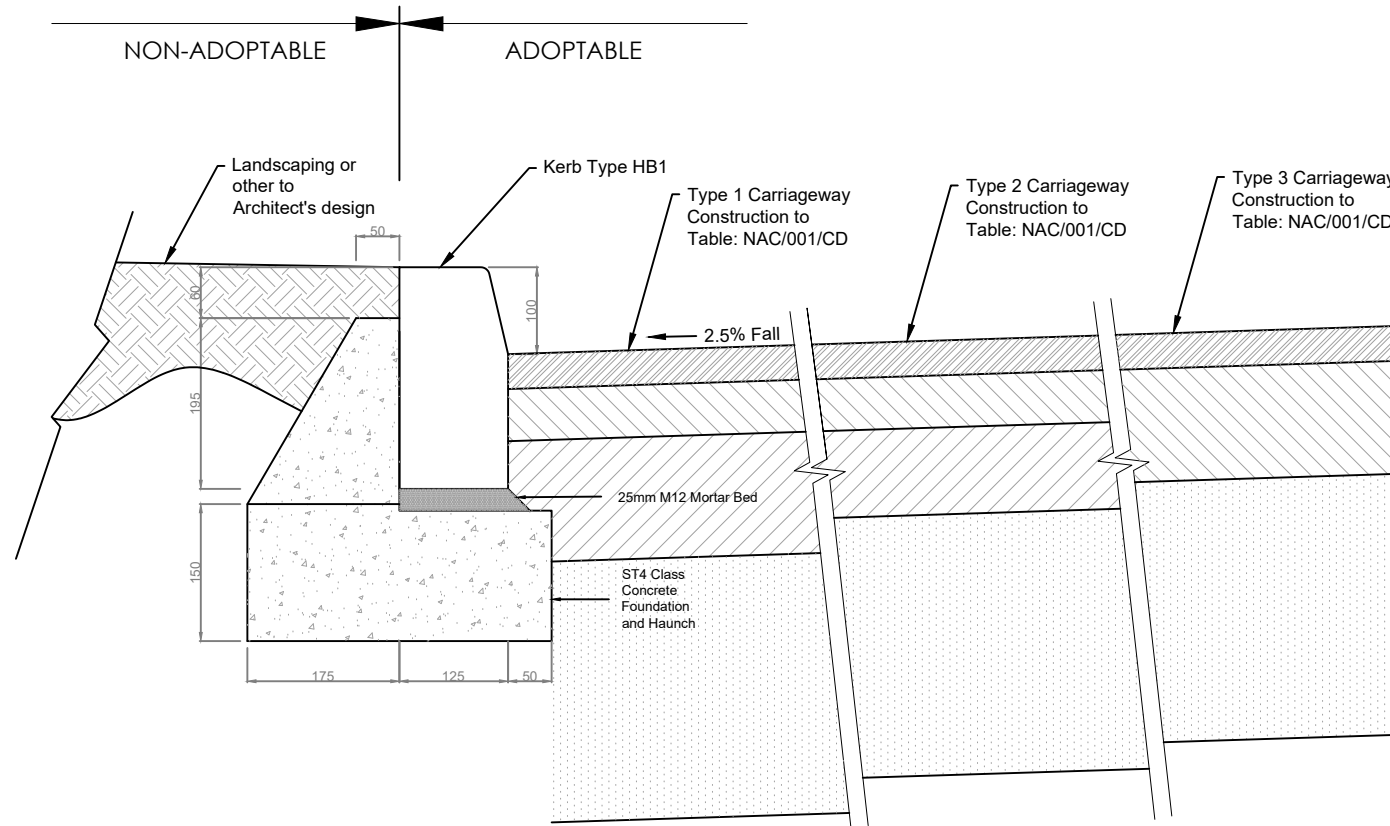

Carriageway Construction				
Road Type	Sub-Base	Base Course	Binder Course	Surface Course
4 (a)	300mm Granular Sub-base Type 1 (cl 803)	80mm Dense Base Course Asphalt Concrete (Recipe Mixture) (cl 906), (AC 32 dense base 100/150 rec)	50mm Dense Binder Course Asphalt Concrete (Recipe Mixture) (cl 906), (AC 20 dense bin 100/150 rec)	40mm Hot Rolled Asphalt Surface Course (Recipe Mixture) (cl 910), (HRA 30/14 F surf 40/60) with Red 14/20mm Uncoated Chipping 40/60 PSV 60 (cl 915)
		130mm Dense Binder Course Asphalt Concrete (Recipe Mixture) (cl 906), (AC 20 dense bin 100/150 rec)		
4 (b)	400mm Granular Sub-base Type 1 (cl 803)	50mm Bedding Layer of Sharp Sand or Crushed Rock (Appendix 7/1)		200 x 100 x 80mm thick Concrete Rectangular Block Paving (cl 1043)



## NOTES

1. All dimensions in millimetres. (This drawing is not to scale)
2. New Kerbing details to comply with drawing as stated
3. Full Construction Information for Carriageway to Table NAC/001/CD

(This drawing is not to scale)

-  SURFACE COURSE
-  BINDER COURSE
-  BASE COURSE
-  SUB-BASE

Carriageway Construction					
Road Type	Sub-Base	Base Course	Binder Course	Surface Course	
1	Connector Streets	300mm Granular Sub-base Type 1 (cl 803)	140mm Dense Base Course Asphalt Concrete (Recipe Mixture (cl 906), (AC 32 dense base 100/150 rec)	60mm Dense Binder Course Asphalt Concrete (Recipe Mixture) (cl 906), (AC 20 dense bin 100/150 rec)	40mm Hot Rolled Asphalt Surface Course (Recipe Mixture) (cl 910), (HRA 30/14 F surf 40/60) with Black 14/20mm Coated Chipping 40/60 PSV 60 (cl 915)
2	Local Residential Streets	300mm Granular Sub-base Type 1 (cl 803)	100mm Dense Base Course Asphalt Concrete (Recipe Mixture (cl 906), (AC 32 dense base 100/150 rec)	60mm Dense Binder Course Asphalt Concrete (Recipe Mixture) (cl 906), (AC 20 dense bin 100/150 rec)	40mm Hot Rolled Asphalt Surface Course (Recipe Mixture) (cl 910), (HRA 30/14 F surf 40/60) with Black 14/20mm Coated Chipping 40/60 PSV 60 (cl 915)
3	Shared Space Streets	300mm Granular Sub-base Type 1 (cl 803)	80mm Dense Base Course Asphalt Concrete (Recipe Mixture (cl 906), (AC 32 dense base 100/150 rec)	50mm Dense Binder Course Asphalt Concrete (Recipe Mixture) (cl 906), (AC 20 dense bin 100/150 rec)	40mm Hot Rolled Asphalt Surface Course (Recipe Mixture) (cl 910), (HRA 30/14 F surf 40/60) with Red 14/20mm Uncoated Chipping 40/60 PSV 60 (cl 915)
			130mm Dense Binder Course Asphalt Concrete (Recipe Mixture) (cl 906), (AC 20 dense bin 100/150 rec)		

## STREET TYPE 1, 2 OR 3 - NO ADJACENT ADOPTABLE ASSET (100mm kerb upstand)

DRAWING NO

REV

NAC/207/SNA1



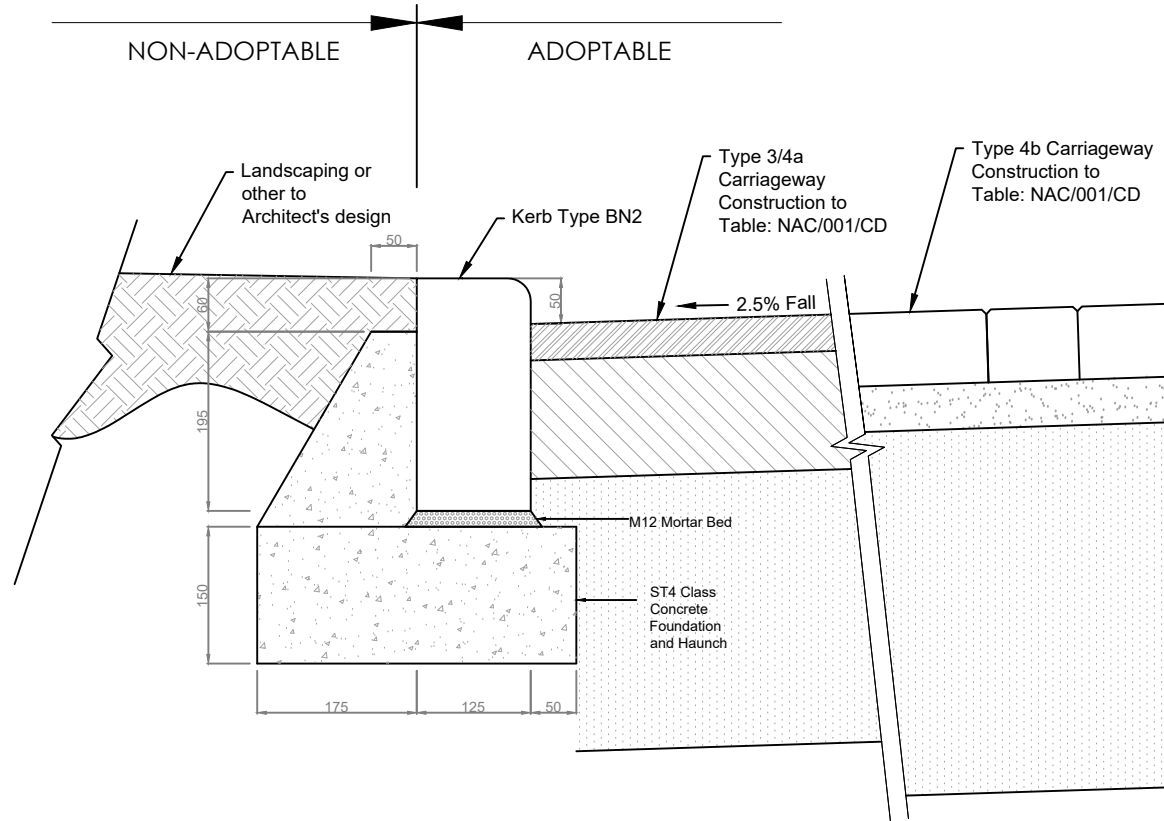

A



## NOTES

1. All dimensions in millimetres. (This drawing is not to scale)
2. New Kerbing details to comply with drawing as stated
3. Full Construction Information for Carriageway to Table NAC/001/CD

(This drawing is not to scale)

-  SURFACE COURSE
-  BINDER COURSE
-  BASE COURSE
-  SUB-BASE

Carriageway Construction					
Road Type		Sub-Base	Base Course	Binder Course	Surface Course
3	Shared Space Streets	300mm Granular Sub-base Type 1 (cl 803)	80mm Dense Base Course Asphalt Concrete (Recipe Mixture (cl 906), (AC 32 dense base 100/150 rec)	50mm Dense Binder Course Asphalt Concrete (Recipe Mixture) (cl 906), (AC 20 dense bin 100/150 rec)	40mm Hot Rolled Asphalt Surface Course (Recipe Mixture) (cl 910), (HRA 30/14 F surf 40/60) with Red 14/20mm Uncoated Chipping 40/60 PSV 60 (cl 915)
			130mm Dense Binder Course Asphalt Concrete (Recipe Mixture) (cl 906), (AC 20 dense bin 100/150 rec)		
4 (a)	Level Surface Streets	300mm Granular Sub-base Type 1 (cl 803)	80mm Dense Base Course Asphalt Concrete (Recipe Mixture (cl 906), (AC 32 dense base 100/150 rec)	50mm Dense Binder Course Asphalt Concrete (Recipe Mixture) (cl 906), (AC 20 dense bin 100/150 rec)	40mm Hot Rolled Asphalt Surface Course (Recipe Mixture) (cl 910), (HRA 30/14 F surf 40/60) with Red 14/20mm Uncoated Chipping 40/60 PSV 60 (cl 915)
			130mm Dense Binder Course Asphalt Concrete (Recipe Mixture) (cl 906), (AC 20 dense bin 100/150 rec)		
4 (b)		400mm Granular Sub-base Type 1 (cl 803)		50mm Bedding Layer of Sharp Sand or Crushed Rock (Appendix 7/1)	200 x 100 x 80mm thick Concrete Rectangular Block Paving (cl 1043)

## STREET TYPE 3 or 4 - NO ADJACENT ADOPTABLE ASSET (50mm kerb upstand)

DRAWING NO

REV

NAC/208/SNA2

A

# NOTES

1. All dimensions in millimetres. (This drawing is not to scale)
  2. New Kerbing details to comply with drawing as stated
  3. Full Construction Information for Carriageway to Table NAC/001/CD
  4. Full Construction Information for Footway to Table NAC/001/CD
  5. Gully detail to drawing NAC/302/GUL
  6. Acceptable Backfill material to be material excavated from within the site or imported on to the site which meets the requirements of S.H.W. Table 6/1 and contract specific Appendix 6/1 for acceptability for use in the permanent works.
- (This drawing is not to scale)

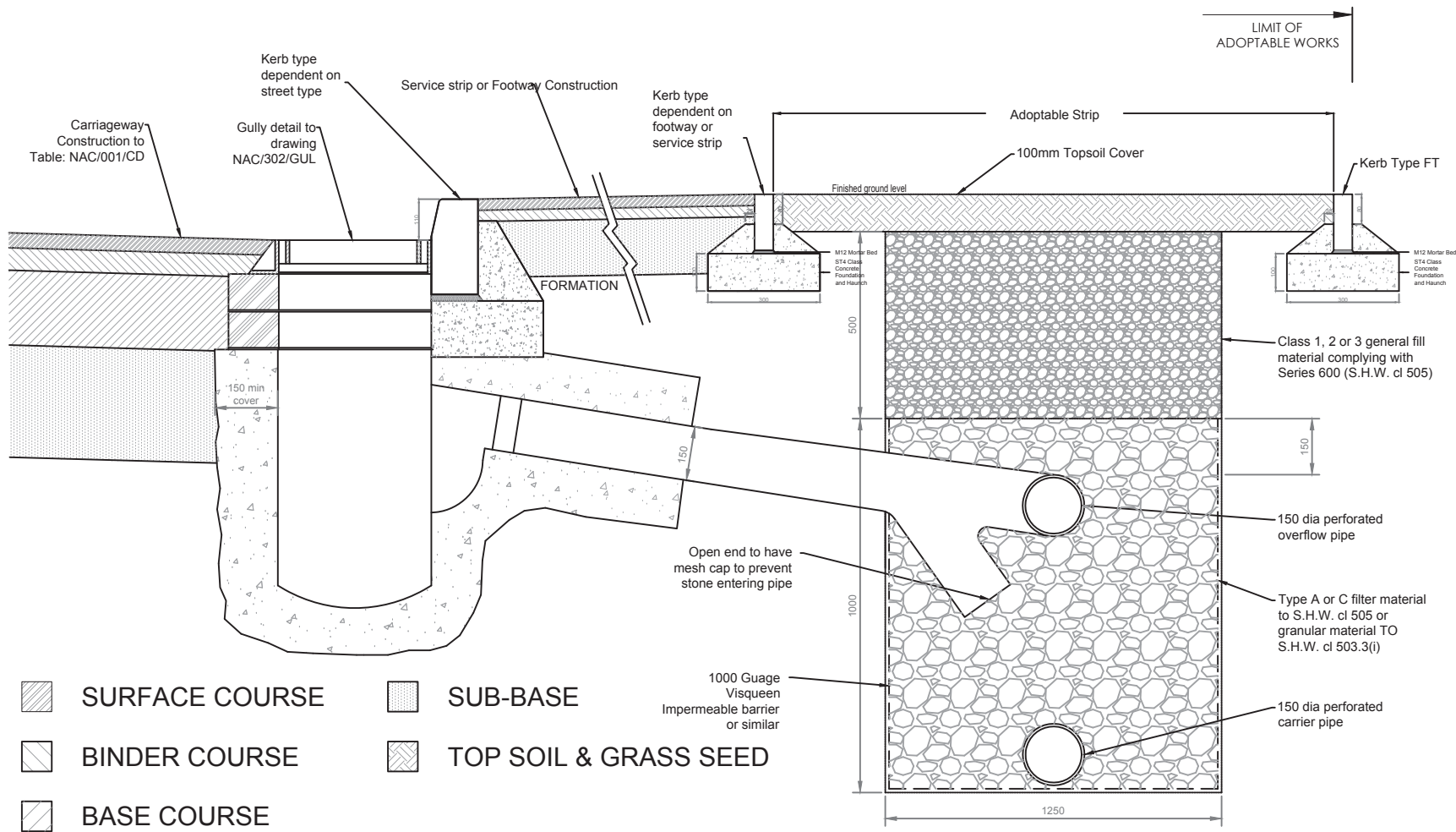

- SURFACE COURSE
- SUB-BASE
- BINDER COURSE
- TOP SOIL & GRASS SEED
- BASE COURSE



## TYPICAL STREET WITH GULLY AND ADJACENT FILTER TRENCH

COPYRIGHT NORTH AYRSHIRE COUNCIL 2019. USED WITH THE PERMISSION OF NORTH AYRSHIRE COUNCIL FOR DEVELOPMENTS WITHIN NORTH AYRSHIRE ONLY.

DRAWING NO	REV
NAC/209/SFT	B

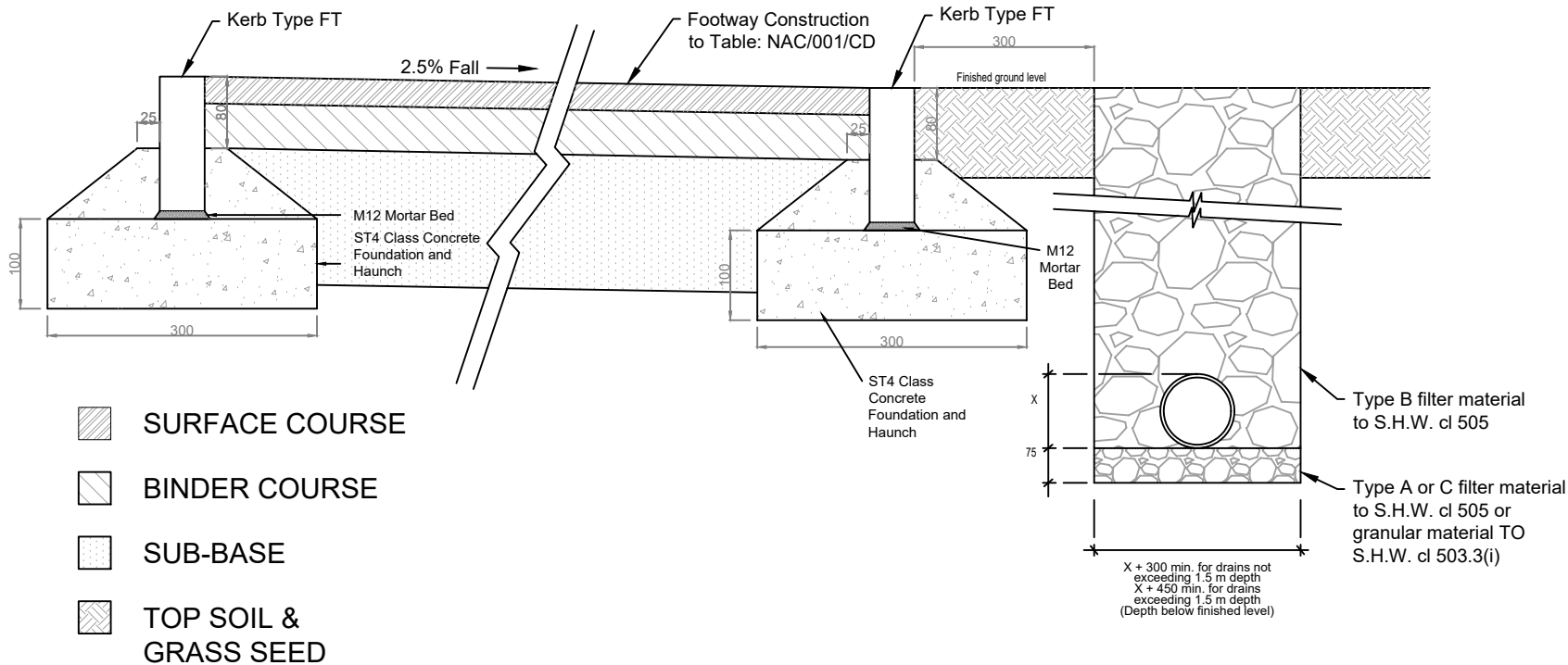

## NOTES

- All dimensions in millimetres. (This drawing is not to scale)
- New Kerbing details to comply with drawing as stated
- Full Construction Information for Footway to Table NAC/001/CD
- Desirably, gradients on footways and footpaths should not exceed 5%, with a nominal maximum of 8%. They should be constructed with crossfall of 3%. Steeper gradients may occasionally be permitted, subject to the provision of a handrail on at least one side and rest platforms at 10 metre intervals.
- Dimension X is the external diameter of the pipe
- This drawing is to be read in conjunction with Appendix 5/1
- Pipes shall comply with the requirements for filter drain pipes in Table 5/1 of the S.H.W.
- Pipes are to be laid with slots or perforations upwards where a concrete bed is used. For other beds the slots shall be orientated as described in Appendix 5/1
- Minimum drain width:  
 X+300 for drains not exceeding 1.5 m depth  
 X+450 for drains exceeding 1.5 m depth  
 (Depth below finished level)

(This drawing is not to scale)

## Footway/path, Cycle Track Construction

Location	Sub-Base	Binder Course	Surface Course
Urban	150mm Granular Sub-base Type 1 (cl 803)	50mm Dense Binder Course Asphalt Concrete (Recipe Mixture) (cl 906), (AC 20 dense bin 100/150 rec)	30mm Hot Rolled Asphalt Surface Course (Recipe Mixture)(cl 910), (HRA 15/10 F surf 40/60)
Rural	200mm Type 1 or recycled suitable material (eg planings)	40mm Close Graded Asphalt Concrete (cl 912) (AC 14 close surf 100/150)	25mm Hot Rolled Asphalt Surface Course (Recipe Mixture) (cl 910), (HRA 15/10 F surf 40/60) or 25mm Close Graded Asphalt Concrete Surface course (cl 912), (AC 10 close surf 100/150)
		Combined 50mm Close Graded Asphalt Concrete Surface course (cl 912) (AC 10 close surf 100/150)	



## NOTES

1. All dimensions in millimetres. (This drawing is not to scale)
2. New Kerbing details to comply with drawing as stated
3. Full Construction Information for Carriageway to Table NAC/001/CD
4. Overrun areas should not have any vertical face which exceeds 6 mm in height and sloping areas should not exceed a slope angle of 15°, measured from the surface of the carriageway.

(This drawing is not to scale)

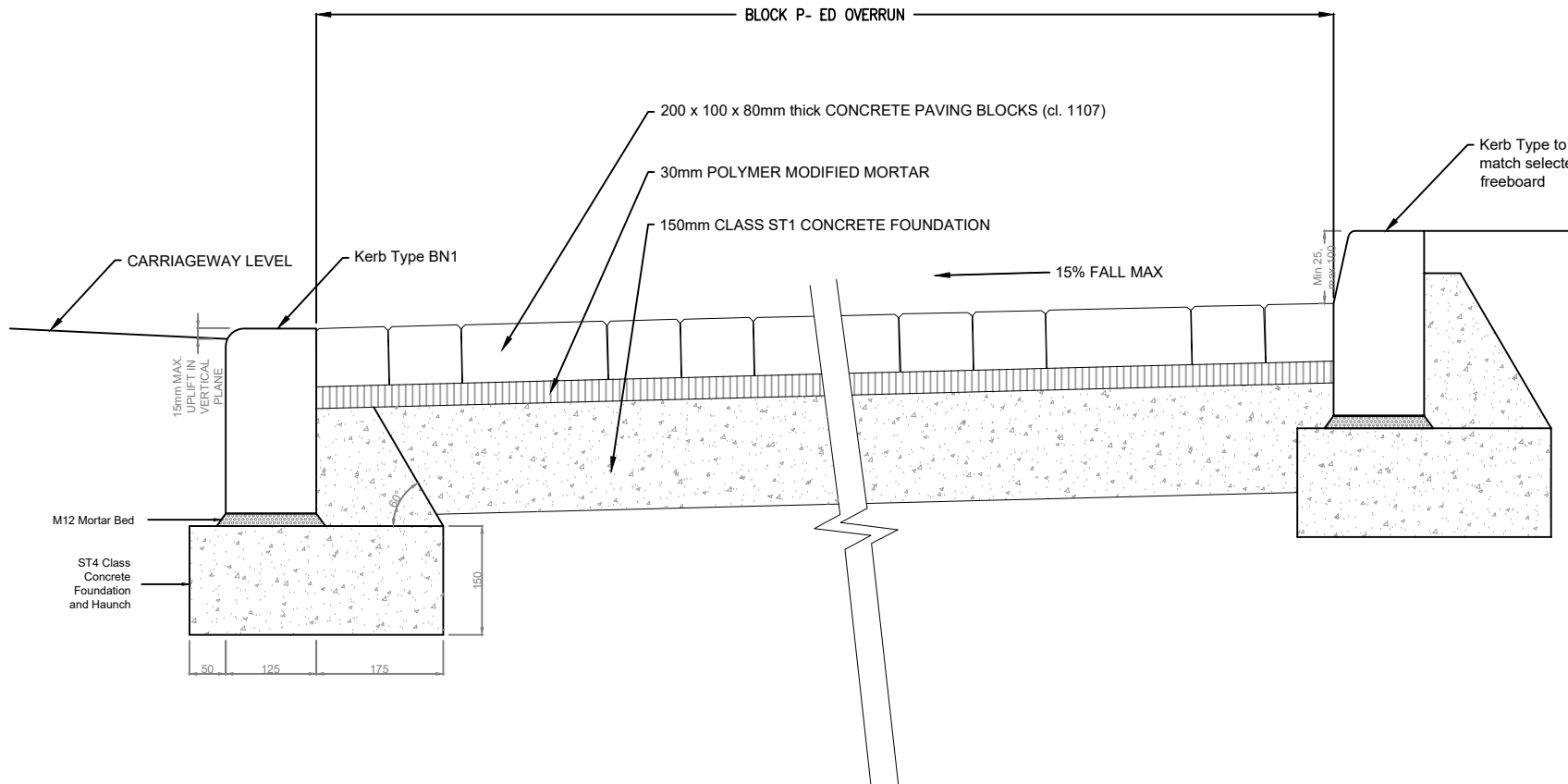

## BLOCK PAVED OVERRUN CONSTRUCTION DETAIL

Shared Space/Level Surface Streets  
(TYPE 3 or 4)





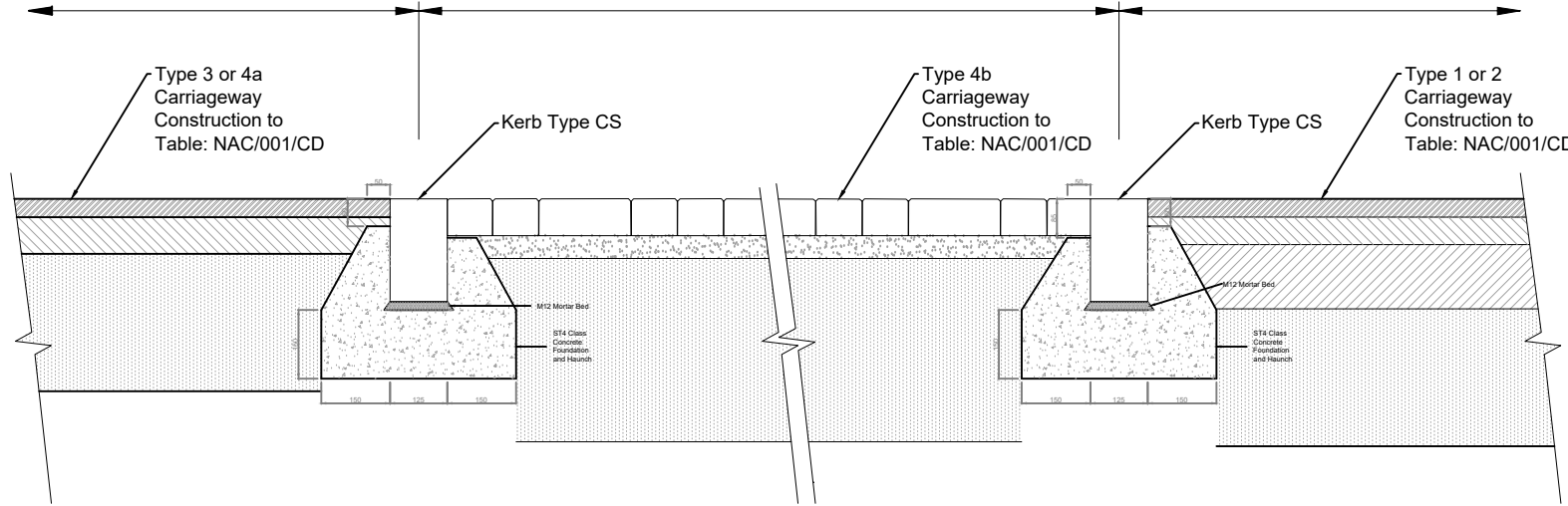

BLOCK PAVED TRANSITION  
(PREFERRED 10M LONG)

Connector/Local Residential Streets  
(TYPE 1 or 2)



NOTES

1. All dimensions in millimetres. (This drawing is not to scale)
  2. New Kerbing details to comply with drawing as stated
  3. Full Construction Information for Carriageway to Table NAC/001/CD
  4. Full Construction Information for Footway to Table NAC/001/CD
- (This drawing is not to scale)

-  BLOCK PAVING
-  SURFACE COURSE
-  BINDER COURSE
-  BASE COURSE
-  SUB-BASE
-  SAND BEDDING
-  TOP SOIL & GRASS SEED

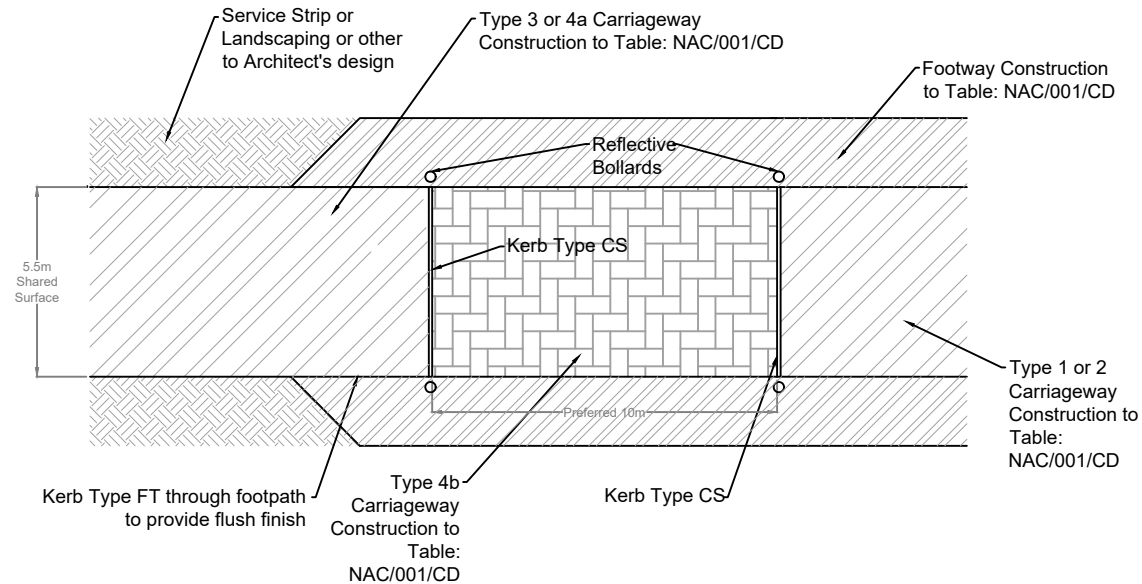







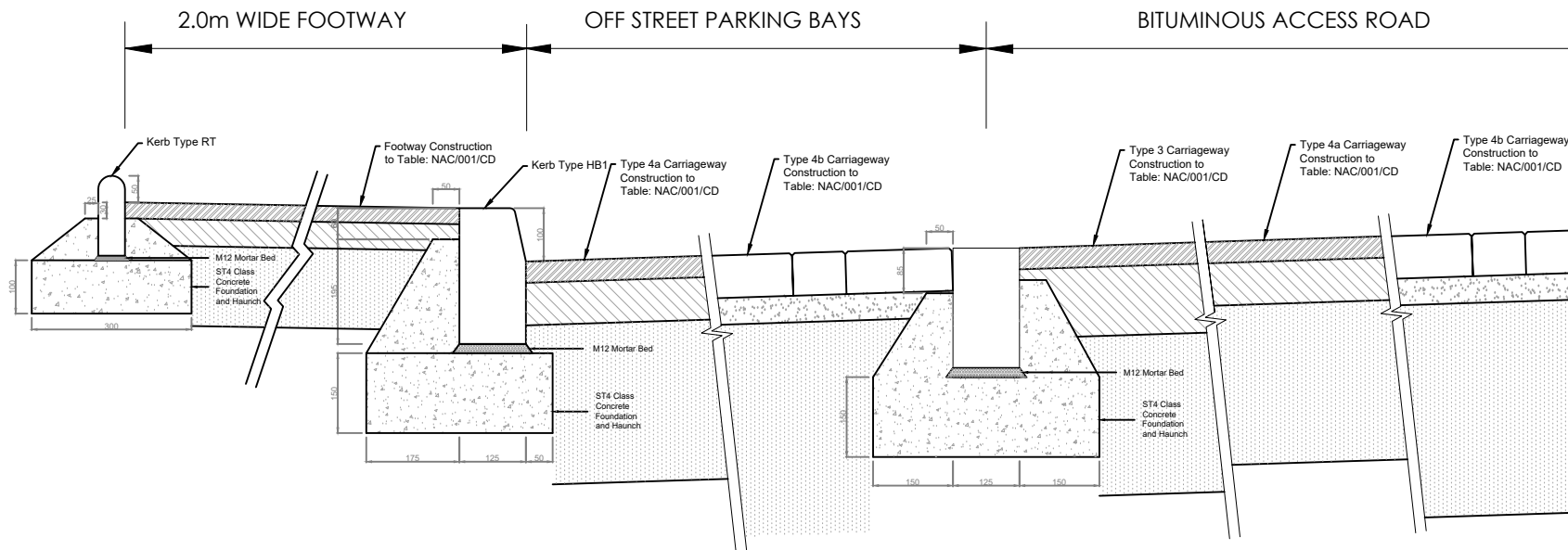

## NOTES

1. All dimensions in millimetres. (This drawing is not to scale)
2. New Kerbing details to comply with drawing as stated
3. Full Construction Information for Carriageway to Table NAC/001/CD
4. Full Construction Information for Footway to Table NAC/001/CD

(This drawing is not to scale)



-  SURFACE COURSE
-  BINDER COURSE
-  BASE COURSE
-  SUB-BASE
-  SAND BEDDING
-  FORMATION

### Carriageway Construction

Road Type	Sub-Base	Base Course	Binder Course	Surface Course	
3	Shared Space Streets	300mm Granular Sub-base Type 1 (cl 803)	80mm Dense Base Course Asphalt Concrete (Recipe Mixture (cl 906), (AC 32 dense base 100/150 rec)	50mm Dense Binder Course Asphalt Concrete (Recipe Mixture) (cl 906), (AC 20 dense bin 100/150 rec)	40mm Hot Rolled Asphalt Surface Course (Recipe Mixture) (cl 910), (HRA 30/14 F surf 40/60) with Red 14/20mm Coated Chipping 40/60 PSV 60 (cl 915)
			130mm Dense Binder Course Asphalt Concrete (Recipe Mixture) (cl 906), (AC 20 dense bin 100/150 rec)		
4 (a)	Level Surface Streets	300mm Granular Sub-base Type 1 (cl 803)	80mm Dense Binder Course Asphalt Concrete (Recipe Mixture) (cl 906), (AC 20 dense bin 100/150 rec)	40mm Hot Rolled Asphalt Surface Course (Recipe Mixture) (cl 910), (HRA 30/14 F surf 40/60) with Red 14/20mm Coated Chipping 40/60 PSV 60 (cl 915)	
4 (b)	Level Surface Streets	400mm Granular Sub-base Type 1 (cl 803)	50mm Bedding Layer of Sharp Sand or Crushed Rock (Appendix 7/1)	200 x 100 x 80mm thick Concrete Rectangular Block Paving (cl 1043) or 200 x 100 x 65mm Concrete Pavers (cl 1107)	

## NOTES

1. -ll dimensions in millimetres.
2. Dimensions taking from the NJUG Guidelines on the Positioning and Colour Coding of Underground Utilities' -pparatus.

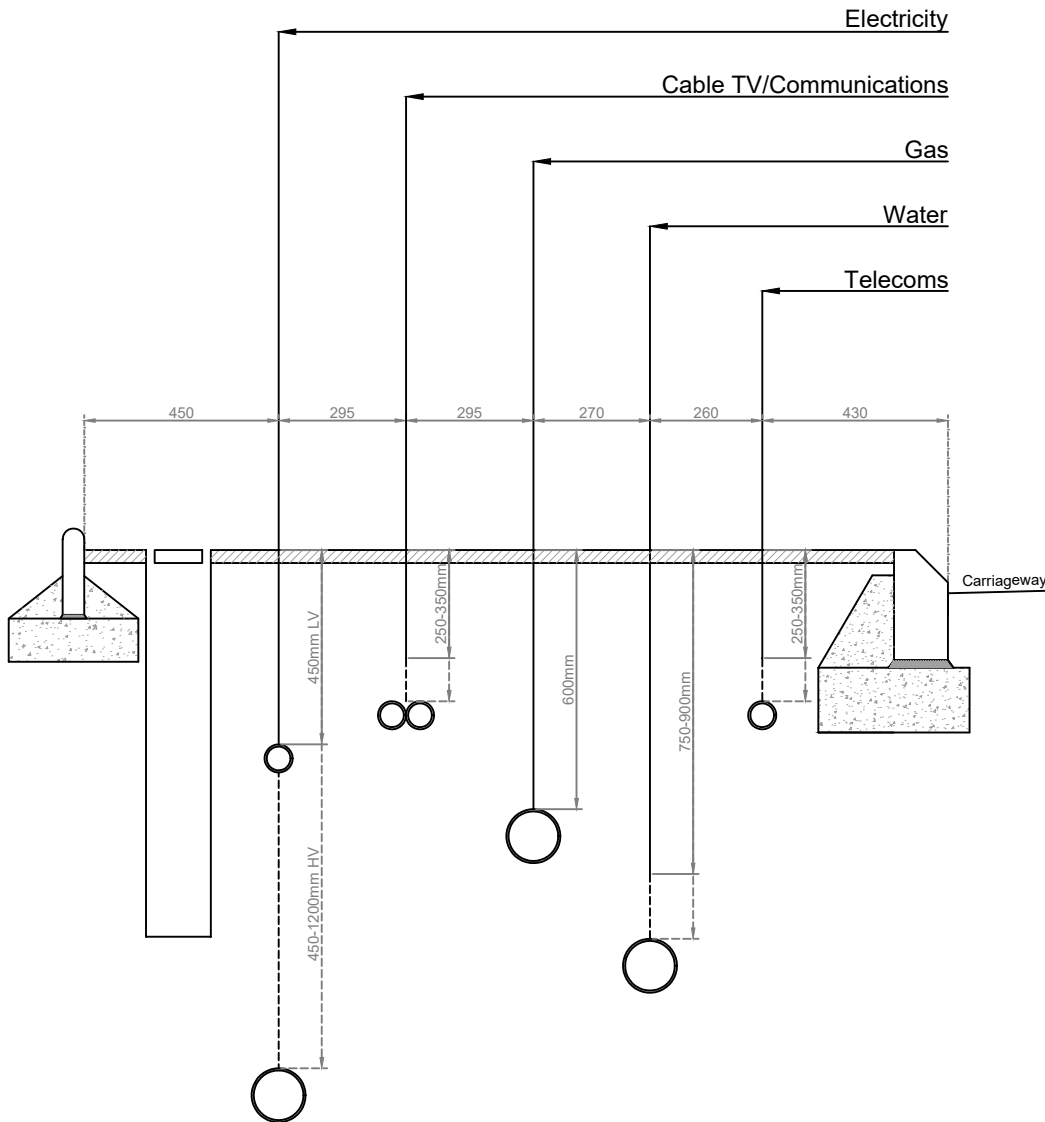

## NOTES

1. -All dimensions in millimetres.
2. Gully grating and frame shall be to BS EN 124
3. Class D400 with Minimum clear opening 450 x 450 bedding and haunched with rapid hardening cement mortar
4. Concrete and bedding mortar to achieve 20N/mm<sup>2</sup> within 2 hours.
5. 150mm Thick ST4 Concrete surround & bed
6. Two course of class B engineering brickwork to be provided on a minimum of 3 sides as a seating for gully frame or 4 sides where no kerb is present
7. 450 x 900 or 375 x 750 Polypropylene Gully Pot
8. Flexible pipe may only be used if agreed by the overseeing organisation

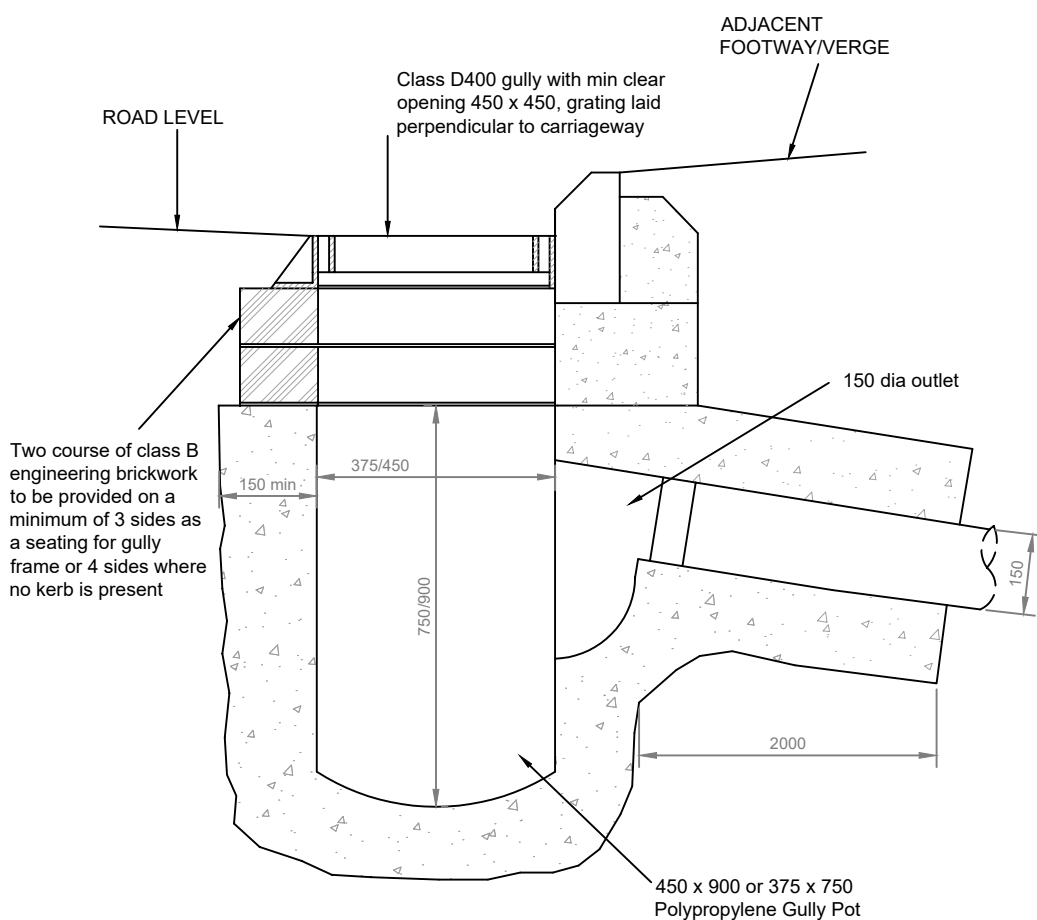

## NOTES

- All dimensions in millimeters.
- Pipelines and manholes to be constructed in accordance with the 'Sewers for Scotland' 3rd edition WRC publication in conjunction with Scottish Water, office specification and requirements.
- Rocker pipes shall be used for pipes less than 750 nominal diameter entering and leaving manholes. Maximum length not to exceed 600mm unless refer to tables 1B.
- All precast concrete units to be reinforced and conform to b.s.5911. Step irons to BS EN 13101 double rungs).
- All joints between p.c. units to be made watertight by the application of cement mortar. "Tokstrip" or other similar approved equal.
- The lowest chamber ring bearing on the foundation and the highest chamber ring receiving the cover slab shall have plain ends and be bedded in cement mortar.
- Manhole access hole and step iron positions to be located to give greatest free area of benching immediately below
- Manhole covers to be class D400 to BS EN 124 double triangular cover & frame 150mm deep with 675mm sq. opening in ductile iron, and bearing the registered certification mark of the british standards institution.
- Step irons not to protrude into 675 square access opening in shaft cover slab.
- Precast concrete cover slabs to be heavy duty.
- Top step iron to be located maximum 675mm from the finished manhole cover level.
- Concrete foundation to be scabbled before placing granolithic finish.
- All metalwork to be hot-dip galvanised to BS 729 after manufacture.
- Buried manholes - covers to be set below ground level (600mm in fields and 300mm in gardens) and covered with a sheet of heavy duty polthene, held in place with waterproof protective tape.

TABLE 1B - TYPE 'B' MANHOLE (0-3m d'p)

MANHOLE DIMENSIONS (mm)		
Pipe Dia (largest diameter)	Mh Dia	Rocker pipe length
150	1200	600
225-300	1200	600
375-450	1350	600

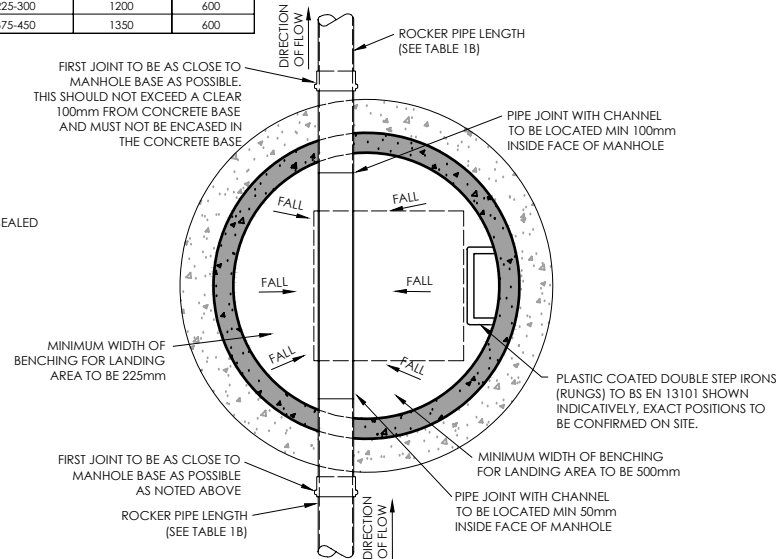
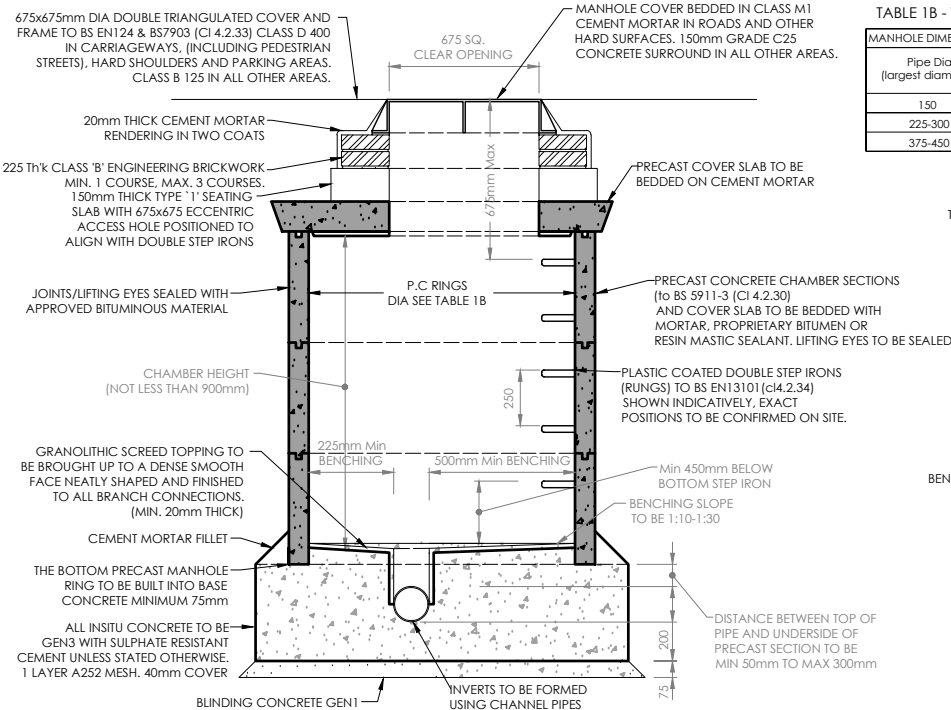

### NOTE:

MIN. COVER TO PIPES WITHOUT CONCRETE PROTECTION:  
1.2m WITHIN ROADWAY, 0.9m WITHIN PARKING.

PIPES WITH LESS THAN THE MIN. COVER SHOULD BE PROTECTED WITH 150mm CONCRETE SURROUND WITH FLEXIBLE JOINTS AT EACH PIPE JOINT.

CONCRETE PROTECTION TO uPVC PIPES:  
150 thk CONCRETE SLAB INSTALLED ABOVE CROWN OF PIPE IN ACCORDANCE WITH Sca.W. DETAILS.

ALL PIPES TO HAVE A 150mm THICK CLASS 'S' GRANULAR PIPE SURROUND UNLESS NOTED OTHERWISE.

### MANHOLE & SILT TRAP COVERS

ADOPTABLE ROADS/  
PRIVATE CARRIAGEWAY/  
PARKING: DUCTILE IRON HEAVY DUTY DOUBLE TRIANGULAR CLASS D400 BY PETER SAVAGE Ltd. OR SIMILAR.

PEDESTRIAN AND LANDSCAPED AREAS: DUCTILE IRON CLASS B125 MEDIUM DUTY BY PETER SAVAGE Ltd OR SIMILAR.

- MANHOLE COVERS WITHIN BUILDINGS TO BE DOUBLE SEALED COVERS
- ALL MANHOLE COVERS TO HAVE BS 'KITEMARK'

# NOTES

- All dimensions in millimeters.
- Pipelines and manholes to be constructed in accordance with the 'Sewers for Scotland' 3rd edition WRC publication in conjunction with Scottish Water, office specification and requirements.
- Rocker pipes shall be used for pipes less than 750 nominal diameter entering and leaving manholes. Maximum length not to exceed 600mm unless refer to tables 1B.
- All precast concrete units to be reinforced and conform to BS EN 124. Step irons to BS EN 13101 double rungs).
- All joints between p.c. units to be made watertight by the application of cement mortar, "Tokstrip" or other similar approved equal.
- The lowest chamber ring bearing on the foundation and the highest chamber ring receiving the cover slab shall have plain ends and be bedded in cement mortar.
- Manhole access hole and step iron positions to be located to give greatest free area of benching immediately below
- Manhole covers to be class D400 to BS EN 124 double triangular cover & frame 150mm deep with 675mm sq. opening in ductile iron, and bearing the registered certification mark of the british standards institution.
- Step irons not to protrude into 675 square access opening in shaft cover slab.
- Precast concrete cover slabs to be heavy duty.
- Top step iron to be located maximum 675mm from the finished manhole cover level.
- Concrete foundation to be scabbled before placing granolithic finish.
- All metalwork to be hot-dip galvanised to BS 729 after manufacture.
- Buried manholes - covers to be set below ground level (600mm in fields and 300mm in gardens) and covered with a sheet of heavy duty polthene, held in place with waterproof protective tape.

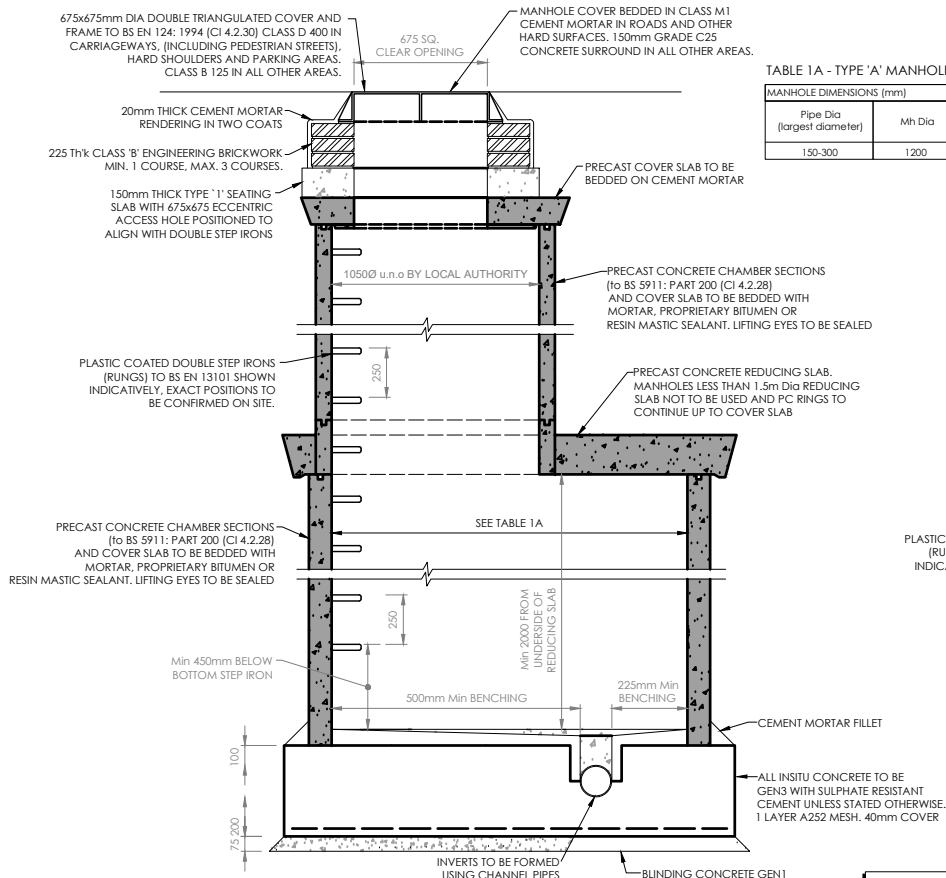
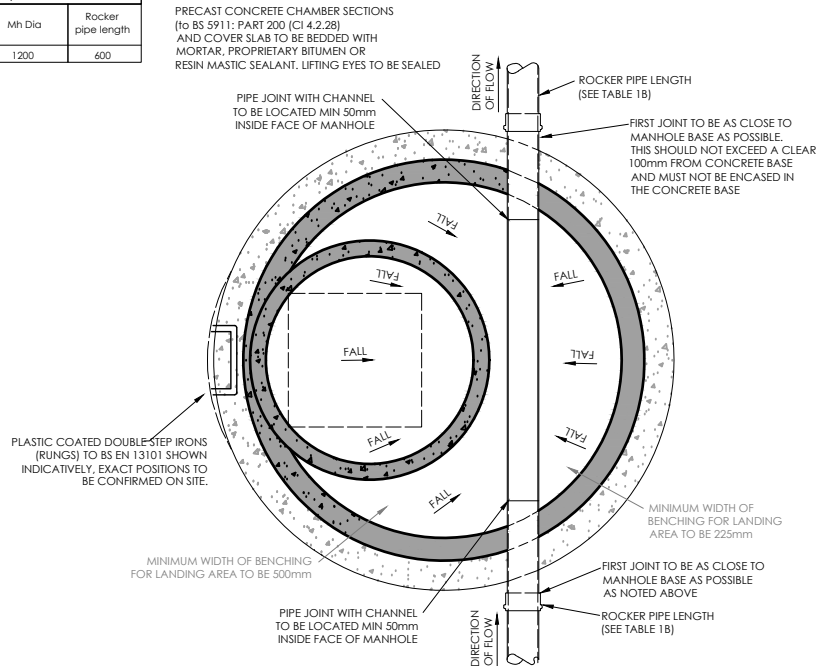

TABLE 1A - TYPE 'A' MANHOLE (3-6m d'p)

MANHOLE DIMENSIONS (mm)		
Pipe Dia (largest diameter)	Mh Dia	Rocker pipe length
150-300	1200	600



**NOTE:**  
 MIN. COVER TO PIPES WITHOUT CONCRETE PROTECTION: 1.2m WITHIN ROADWAY, 0.9m WITHIN PARKING.  
 PIPES WITH LESS THAN THE MIN. COVER SHOULD BE PROTECTED WITH 150mm CONCRETE SURROUND WITH FLEXIBLE JOINTS AT EACH PIPE JOINT.  
 CONCRETE PROTECTION TO uPVC PIPES: 150 THK CONCRETE SLAB INSTALLED ABOVE CROWN OF PIPE IN ACCORDANCE WITH S.C.O.W. DETAILS.  
 ALL PIPES TO HAVE A 150mm THICK CLASS 'S' GRANULAR PIPE SURROUND UNLESS NOTED OTHERWISE.

**MANHOLE & SILT TRAP COVERS**

ADAPTABLE ROADS/ PRIVATE CARRIAGEWAY/ PARKING:	DUCTILE IRON HEAVY DUTY DOUBLE TRIANGULAR CLASS D400 BY PETER SAVAGE Ltd. OR SIMILAR.
PEDESTRIAN AND LANDSCAPED AREAS:	DUCTILE IRON CLASS B125 MEDIUM DUTY BY PETER SAVAGE Ltd OR SIMILAR.
<ul style="list-style-type: none"> <li>MANHOLE COVERS WITHIN BUILDINGS TO BE DOUBLE SEALED COVERS</li> <li>ALL MANHOLE COVERS TO HAVE BS 'KITEMARK'</li> </ul>	



## TYPE A MANHOLE - DEPTH 3 TO 6 METRES (to be used within carriageway)

COPYRIGHT NORTH AYRSHIRE COUNCIL 2019. USED WITH THE PERMISSION OF NORTH AYRSHIRE COUNCIL FOR DEVELOPMENTS WITHIN NORTH AYRSHIRE ONLY.

DRAWING NO	REV
NAC/304/MH2	A

## NOTES

- All dimensions in millimeters.
- Pipelines and manholes to be constructed in accordance with the 'Sewers for Scotland' 3rd edition WRC publication in conjunction with Scottish Water, office specification and requirements.
- Rocker pipes shall be used for pipes less than 750 nominal diameter entering and leaving manholes. Maximum length not to exceed 600mm unless refer to tables 1B.
- All precast concrete units to be reinforced and conform to b.s.5911. Step irons to BS EN 13101 double rungs).
- All joints between p.c. units to be made watertight by the application of cement mortar. "Tokstrip" or other similar approved equal.
- The lowest chamber ring bearing on the foundation and the highest chamber ring receiving the cover slab shall have plain ends and be bedded in cement mortar.
- Manhole access hole and step iron positions to be located to give greatest free area of benching immediately below
- Manhole covers to be class D400 to BS EN 124 double triangular cover & frame 150mm deep with 675mm sq. opening in ductile iron. and bearing the registered certification mark of the british standards institution.
- Step irons not to protrude into 675 square access opening in shaft cover slab.
- Precast concrete cover slabs to be heavy duty.
- Top step iron to be located maximum 675mm from the finished manhole cover level.
- Concrete foundation to be scabbled before placing granolithic finish.
- All metalwork to be hot-dip galvanised to BS 729 after manufacture.
- Buried manholes - covers to be set below ground level (600mm in fields and 300mm in gardens) and covered with a sheet of heavy duty polthene, held in place with waterproof protective tape.

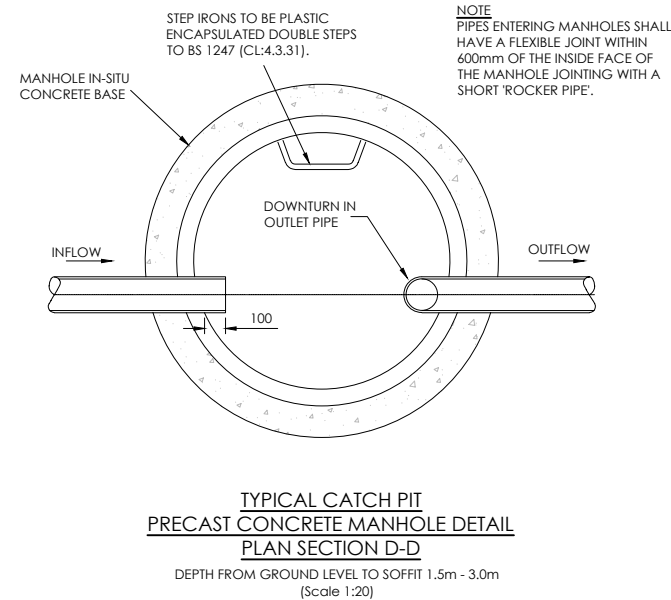
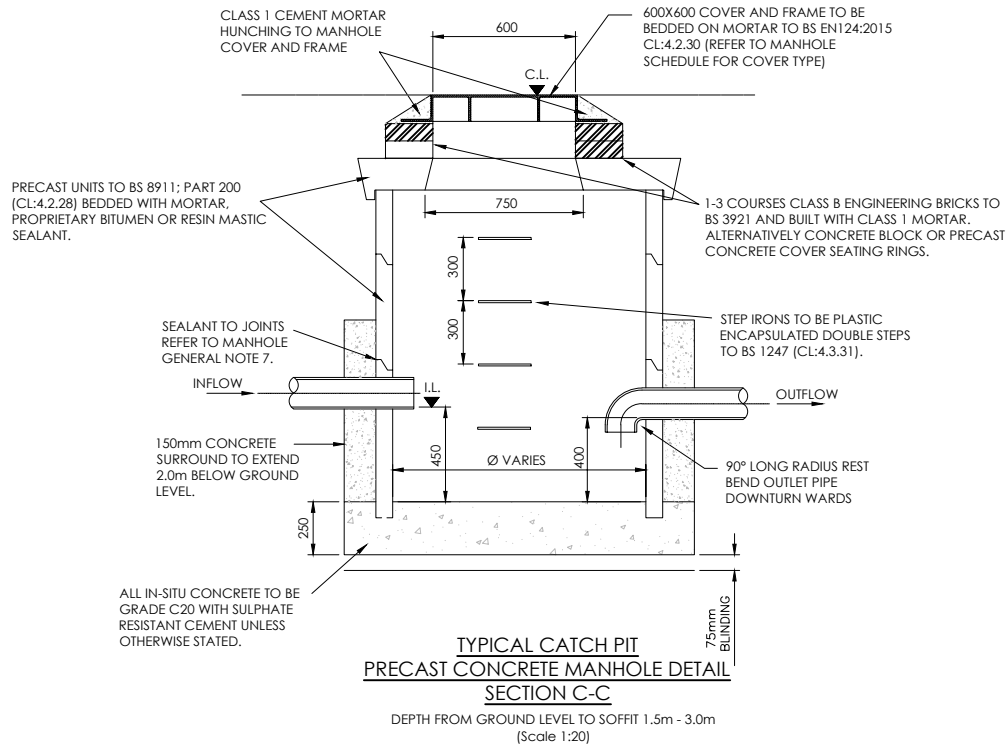

# CATCHPIT (to be used outwith carriageway)

## NOTES

1. -All dimensions in millimetres.
2. This chamber is for use where the pipe diameter does not exceed 225 mm.
3. Two number 22.5° bends shall be used to connect the drop pipe to the main pipe.
4. The drop pipe and bend shall be surrounded with 150 mm thick concrete GEN 1 with consistence class S1 complying with BS 8500-1:2006 + -1:2012.
5. Except for corrugated pipes, the nearest joint in the main pipe shall form part of an articulated section and be not more than 500 mm from the bend.
6. Chamber base to be cast in situ in concrete GEN 1 with consistence class S3 complying with BS 8500-1:2006 + -1:2012 with a smooth finish to Class U3.
7. The drop pipe shall be cast into chamber base.
8. One to two courses of Class B engineering brick to BS EN 771-1:2003, 225 mm thick to be provided to adjust final level of rodding eye cover.
9. Rodding eye cover to be to BS EN 124:1994, Class D400. -All mortar to be M12 except that the cover frame shall be bedded on epoxy resin mortar.
10. For construction of all buried pipes, refer to BS 9295:2010.

(This drawing is not to scale)

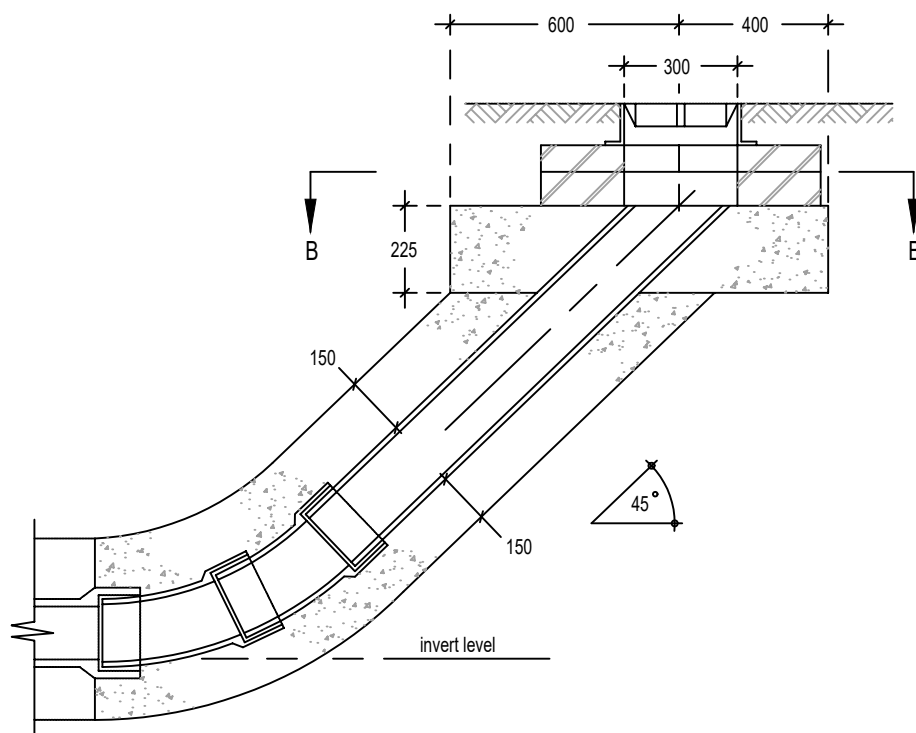

SECTIONAL ELEVATION AA

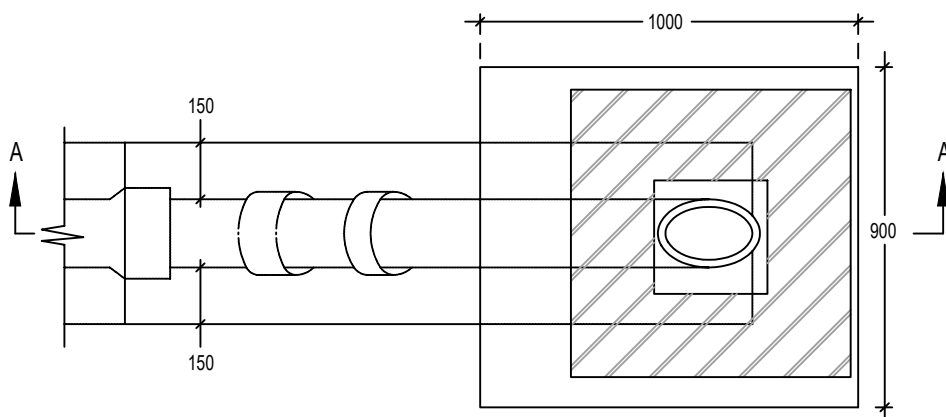

SECTIONAL PLAN BB

## NOTES

1. All dimensions in millimeters.
2. This drawing is to be read in conjunction with Appendix 5/1.
3. Dimension X is the external diameter of the pipe.
4. The minimum or maximum width of the trench applies on and below a line 300mm above the outside top of the pipe. Above the 300mm line, the trench backfill material shall be as described in Clause 505 of SHW.
5. The concrete bed or surround may extend to the sides of the trench or be of minimum width. Class 8 material is to be used to fill any voids so formed.
6. For Type Z trench the concrete cover may be formed to a radius batter or horizontal surface. Minimum cover of concrete shall be 150mm.

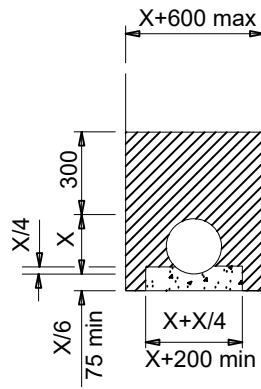

TYPE A

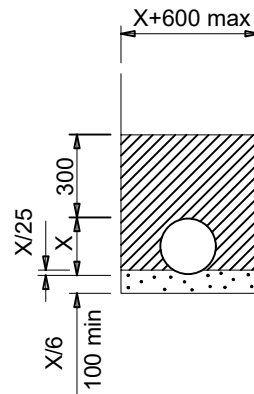

TYPE F

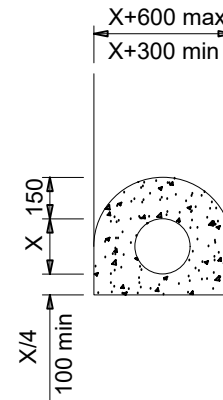

TYPE Z

### KEY



Granular material to S.H.W. Clause 503.3(i).



Concrete to S.H.W. Clause 503.3 (iii)



Class 8 material to S.H.W. Clause 503.3(iv).



## NOTES

1. All dimensions in millimetres. (This drawing is not to scale)
2. New Kerbing details to comply with drawing as stated
3. Full Construction Information for Carriageway to Table NAC/001/CD
4. Full Construction Information for Footway to Table NAC/001/CD
5. This drawing to be read in junction with drawing NAC/309/FLT2
6. Gully detail to drawing NAC/302/GUL
7. Acceptable Backfill material to be material excavated from within the site or imported on to the site which meets the requirements of S.H.W. Table 6/1 and contract specific Appendix 6/1 for acceptability for use in the permanent works.

(This drawing is not to scale)

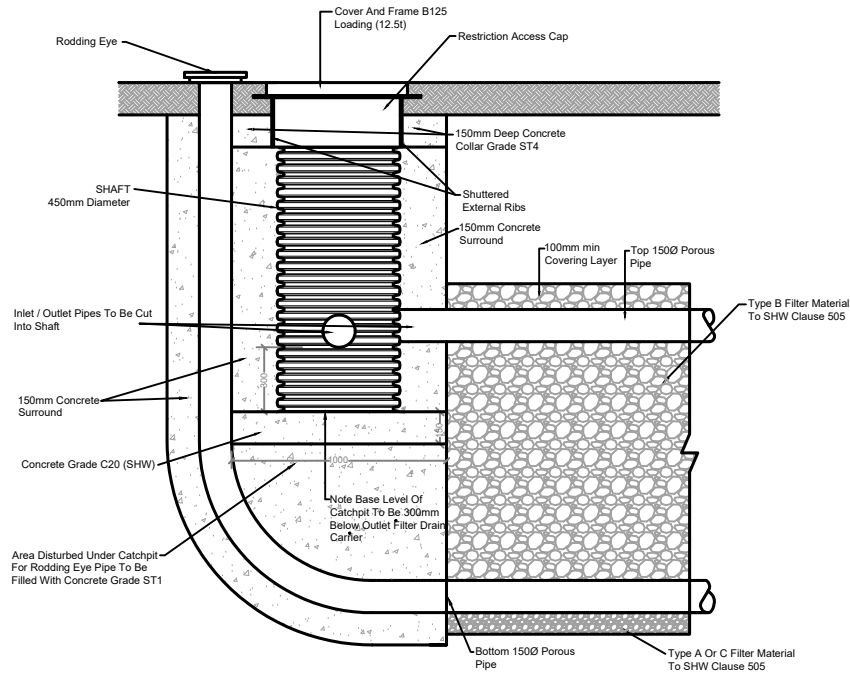

INLET FILTER TRENCH CATCHPIT DETAIL

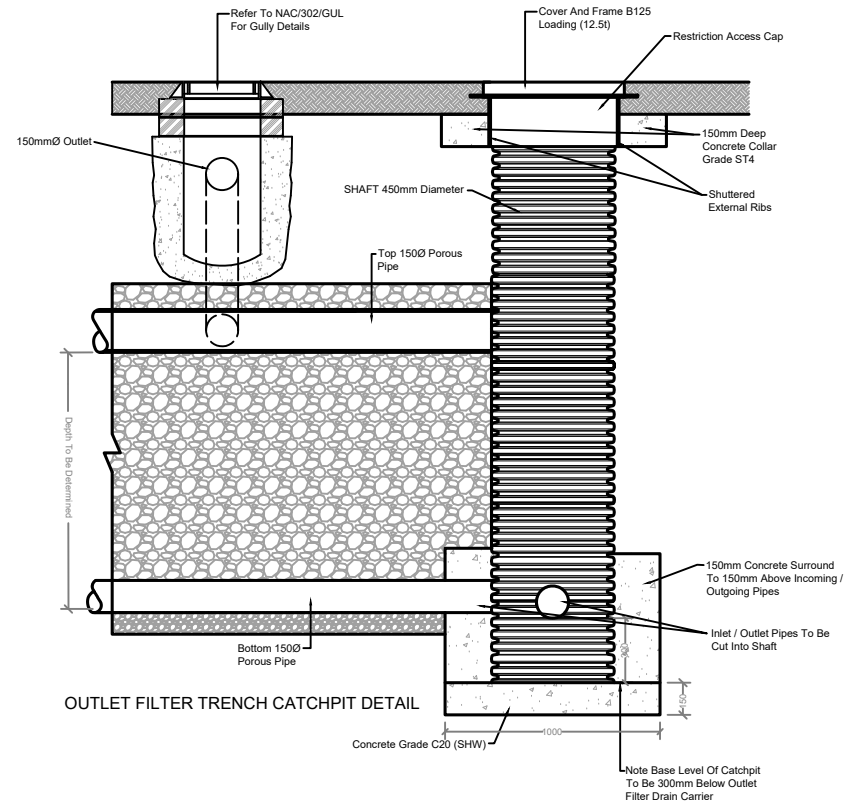

OUTLET FILTER TRENCH CATCHPIT DETAIL

## NOTES

1. All dimensions in millimetres. (This drawing is not to scale)
2. New Kerbing details to comply with drawing as stated
3. Full Construction Information for Carriageway to Table NAC/001/CD
4. Full Construction Information for Footpath to Table NAC/001/CD
5. This drawing to be read in junction with drawing NAC/308/FLT1
6. Gully detail to drawing NAC/302/GUL
7. Acceptable Backfill material to be material excavated from within the site or imported on to the site which meets the requirements of S.H.W. Table 6/1 and contract specific Appendix 6/1 for acceptability for use in the permanent works.

(This drawing is not to scale)

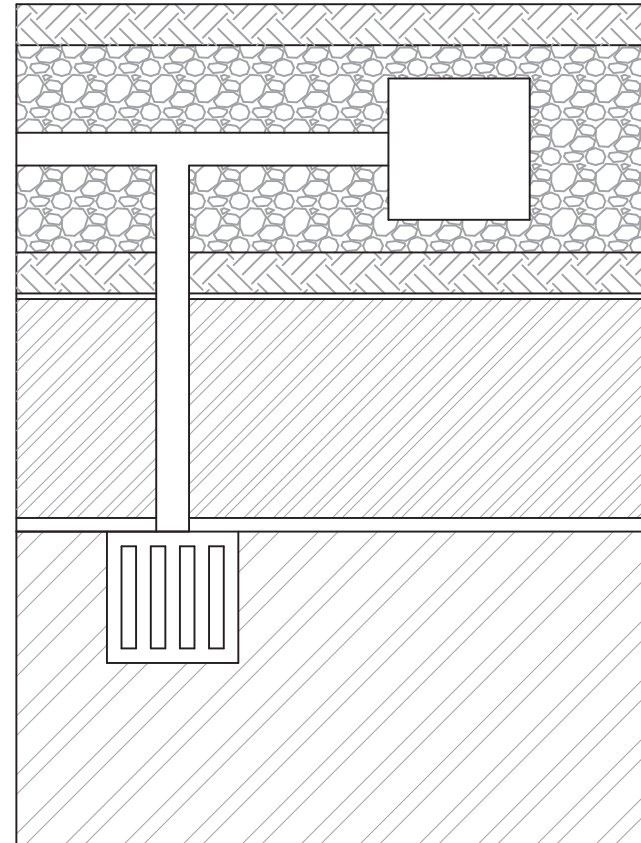
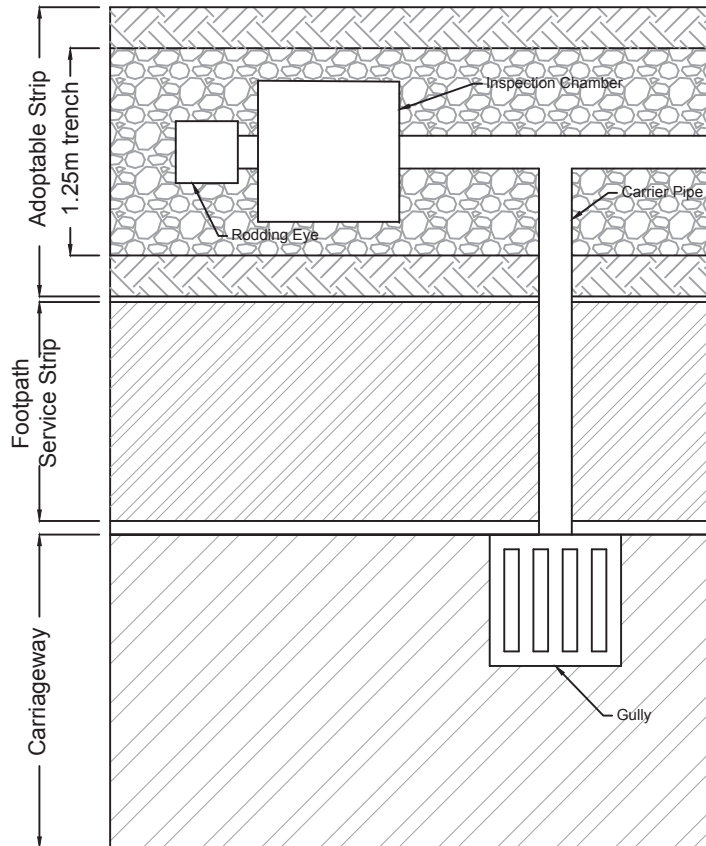

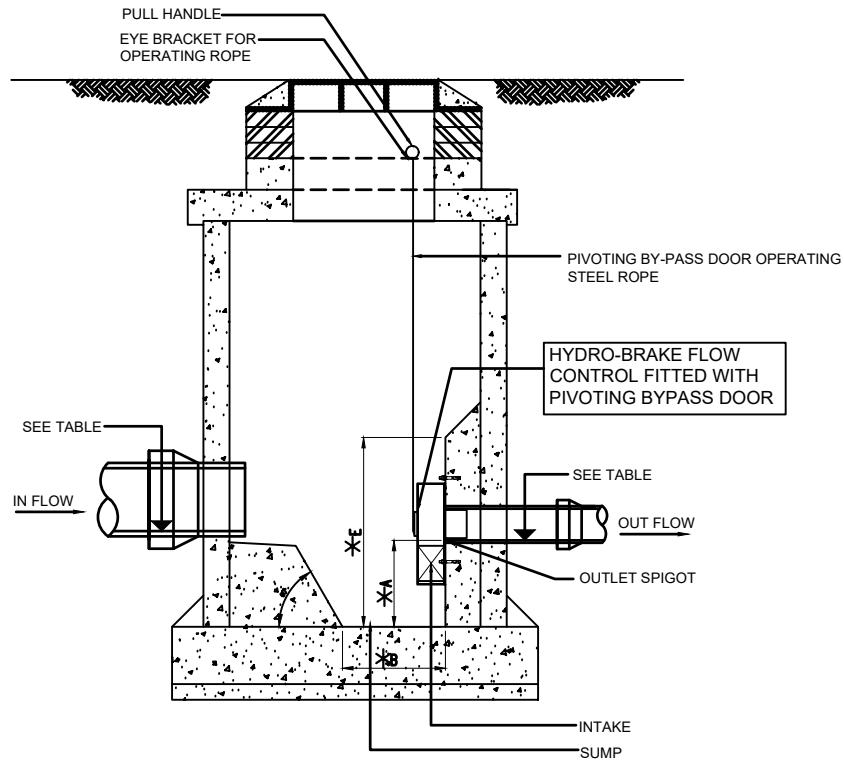

PRECAST CONCRETE HYDRO-BRAKE MANHOLE

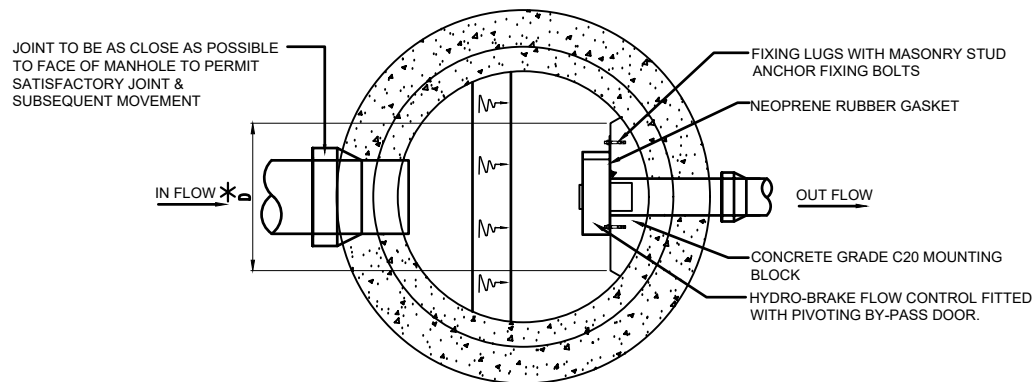

PLAN ON HYDRO-BRAKE MANHOLE

TABLE

INTERNAL DIAMETER OF LOWER PIPE (mm)	INTERNAL DIAMETER OF UPPER PIPE (mm)	'X' mm	'Z' mm	'H' mm	'A' mm	'D' mm	'W' mm
150	150	150	150	375	300	652	1156
150	225	150	150	375	300	704	1239
150	300	150	150	375	300	748	1328
150	375	250	150	375	400	880	1610
150	450	250	150	375	400	921	1693
150	525	250	150	375	400	962	1775
150	600	275	150	375	425	1028	1908
225	225	150	150	375	300	736	1322
225	300	150	150	375	300	781	1411
225	375	250	150	375	400	922	1693
225	450	250	150	375	400	963	1776
225	525	250	150	375	400	1004	1858
225	600	275	150	375	425	1071	1991
300	300	150	150	375	300	825	1500
300	375	250	150	375	400	966	1782
300	450	250	150	375	400	1007	1865
300	525	250	150	375	400	1048	1947
300	600	275	150	375	425	1115	2080

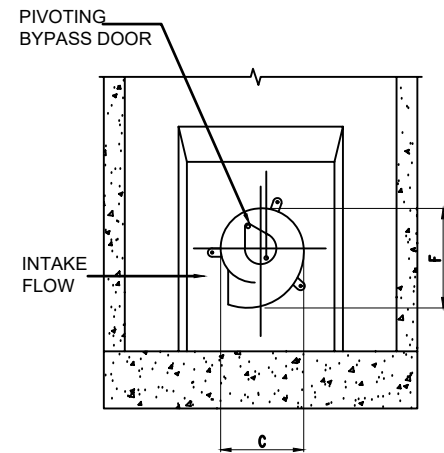

SECTION ON HYDRO-BRAKE

NOTES

1. All dimensions in millimeters.
2. All Hydrobrakes should provide the flow capacities indicated on drainage layout drawings.
3. The minimum orifice size for all hydrobrake to be 75mm diameter and calculations provided by supplier to engineer for approval.

HYDROBRAKE CHAMBER

# NOTES

1. All dimensions in millimetres. (This drawing is not to scale)

(This drawing is not to scale)

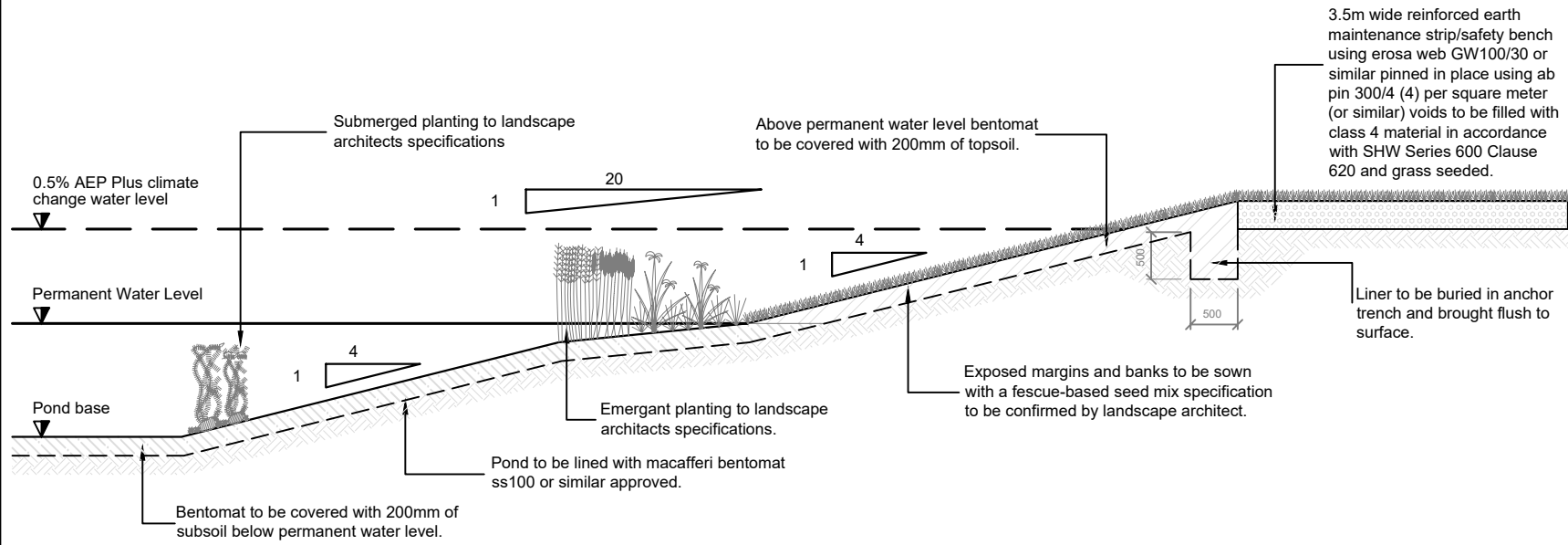

## TYPICAL SECTION THROUGH POND MARGIN

# NOTES

1. All dimensions in millimetres. (This drawing is not to scale)
2. For Inlet detail refer to drawing NAC/313/PI
3. For Outlet detail refer to drawing NAC/314/PO

(This drawing is not to scale)

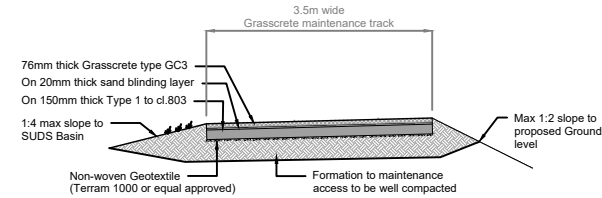

**TYPICAL SECTION - GRASSCRETE MAINTENANCE TRACK**

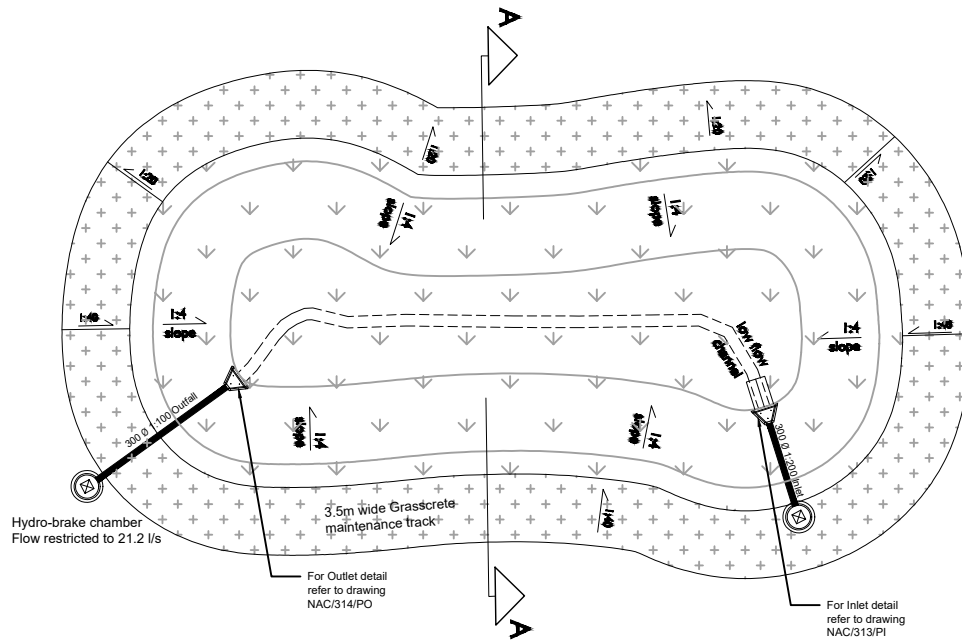

**TYPICAL PLAN - SUDS BASIN**

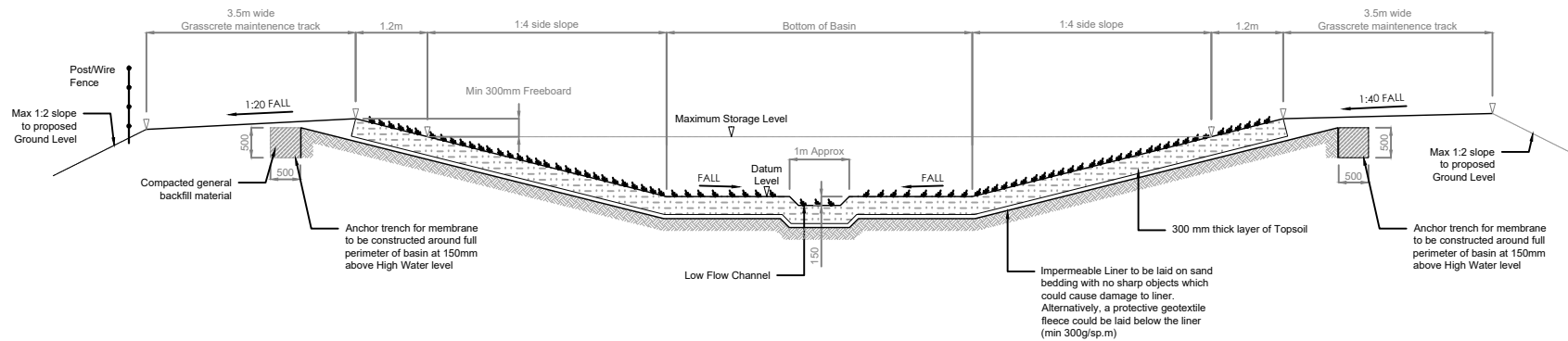

**TYPICAL SECTION A-A THROUGH SUDS BASIN**

## NOTES

1. All dimensions in millimetres. (This drawing is not to scale)
2. This drawing should be read in conjunction with drawings NAC/312/PB, NAC/314/PO and NAC/315/PSG

(This drawing is not to scale)

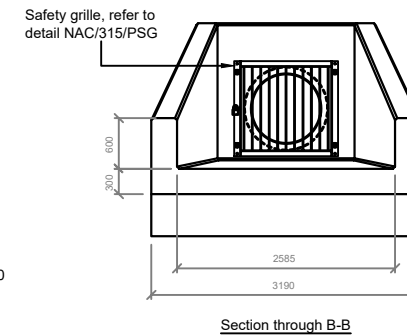
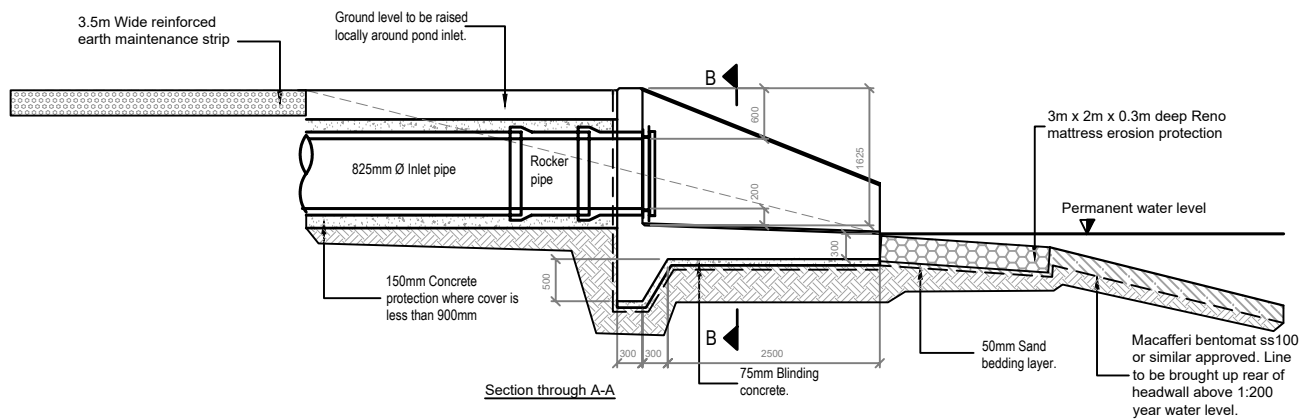
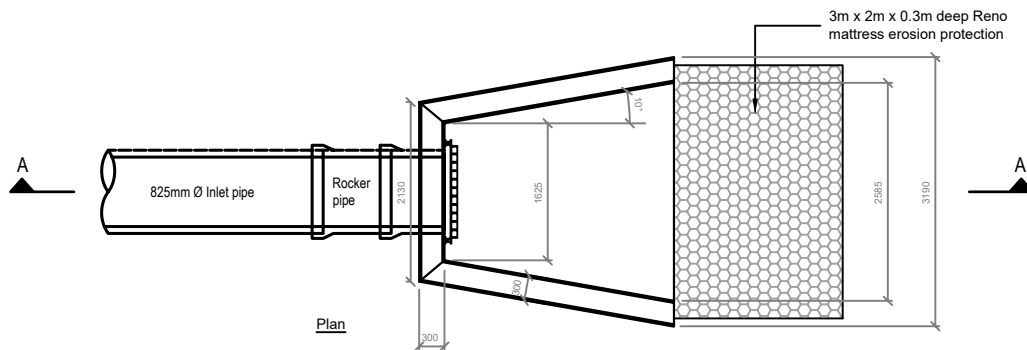



## NOTES

1. All dimensions in millimetres. (This drawing is not to scale)
2. This drawing should be read in conjunction with drawings NAC/312/PB, NAC/313/PI and NAC/314/PO

(This drawing is not to scale)

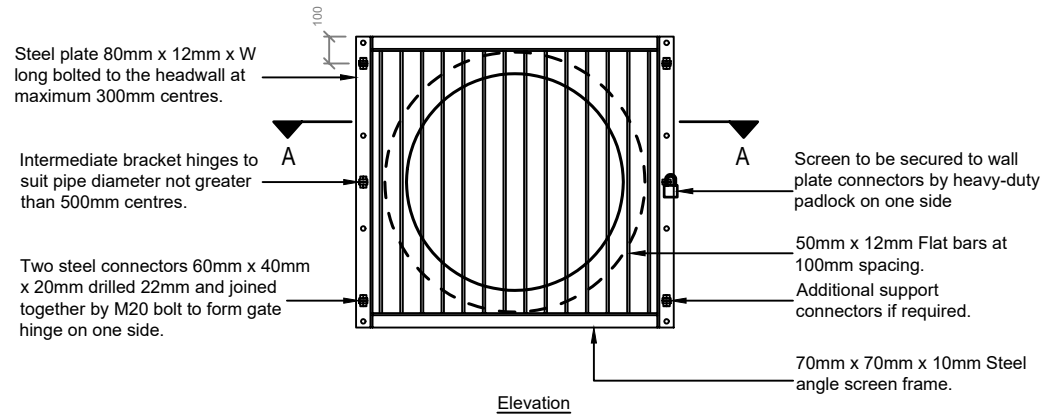

825mm Ø Pipe external diameter taken as 985mm  
450mm Ø Pipe external diameter taken as 575mm  
External diameter based on available pipe dimensions to be confirmed on site

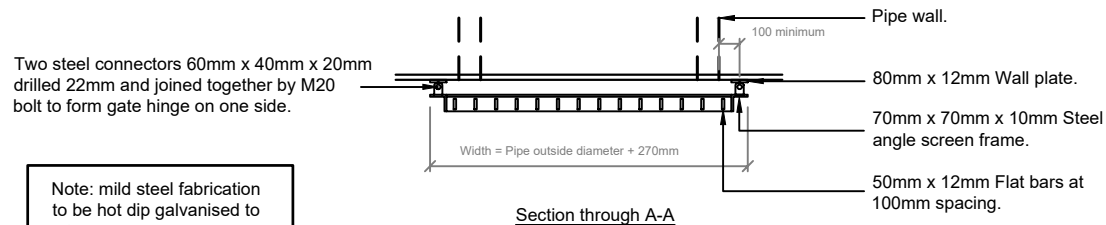
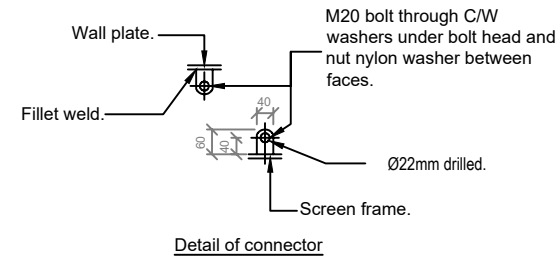

Note: mild steel fabrication to be hot dip galvanised to BS EN 1461



3.6m Universal hanging field gate by Jacksons Fencing or similar approved.

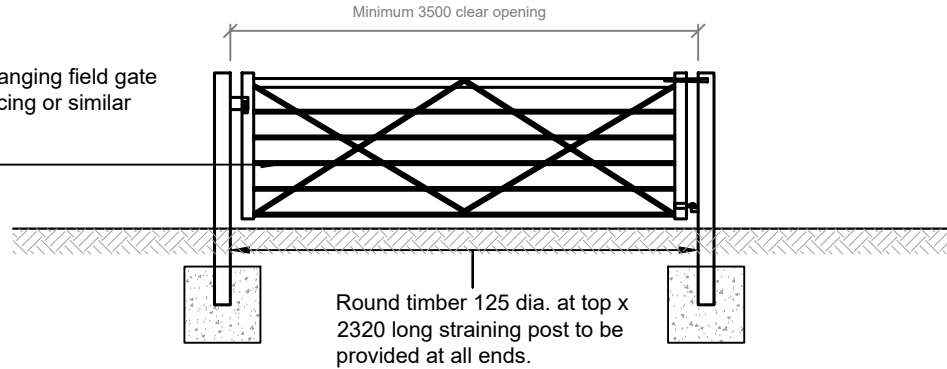

Round timber 125 dia. at top x 2320 long straining post to be provided at all ends.

Typical access gate detail



Signage to be attached to fence

NOTES

1. All dimensions in millimetres. (This drawing is not to scale)
- (This drawing is not to scale)

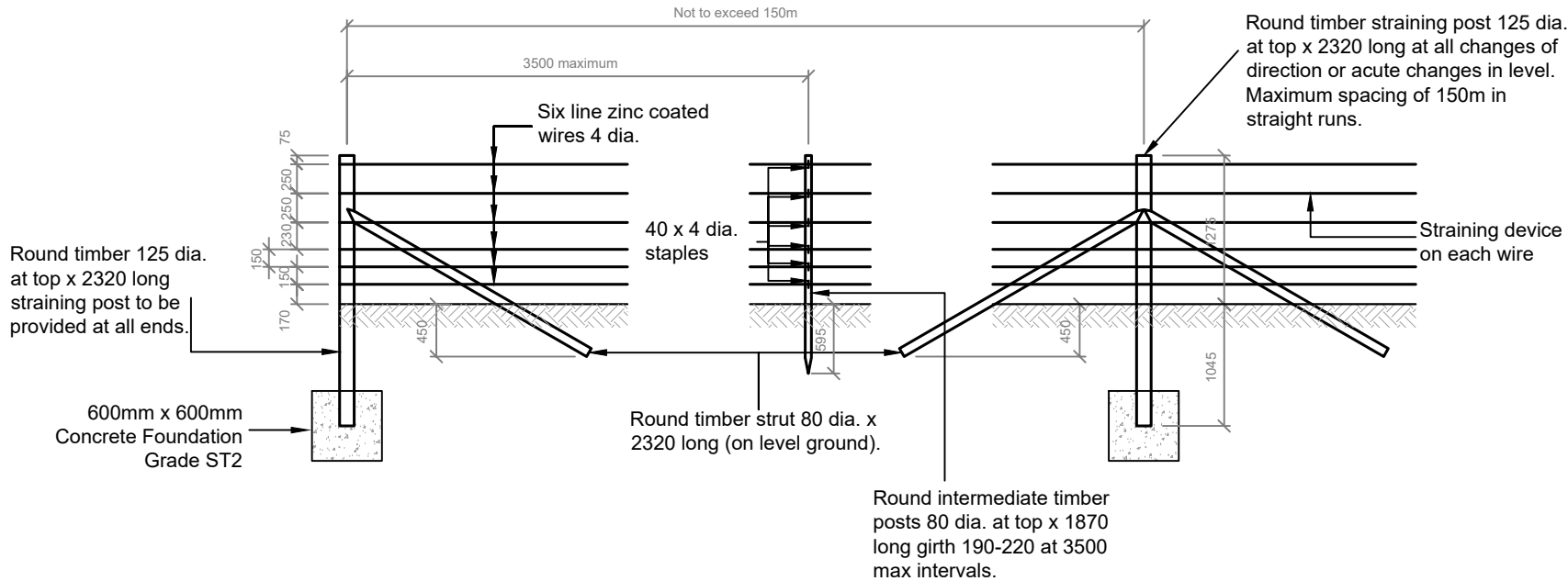

Typical perimeter fence detail

## NOTES

1. All dimensions in millimetres. (This drawing is not to scale)

(This drawing is not to scale)

150mmØ perforated pipe between chambers.

150mmØ outlet to proposed mainline surface system

### SILT TRAP

Polypropylene silt trap with open grill cover to allow surface water from embankment to enter prior to discharging to proposed surface water network.

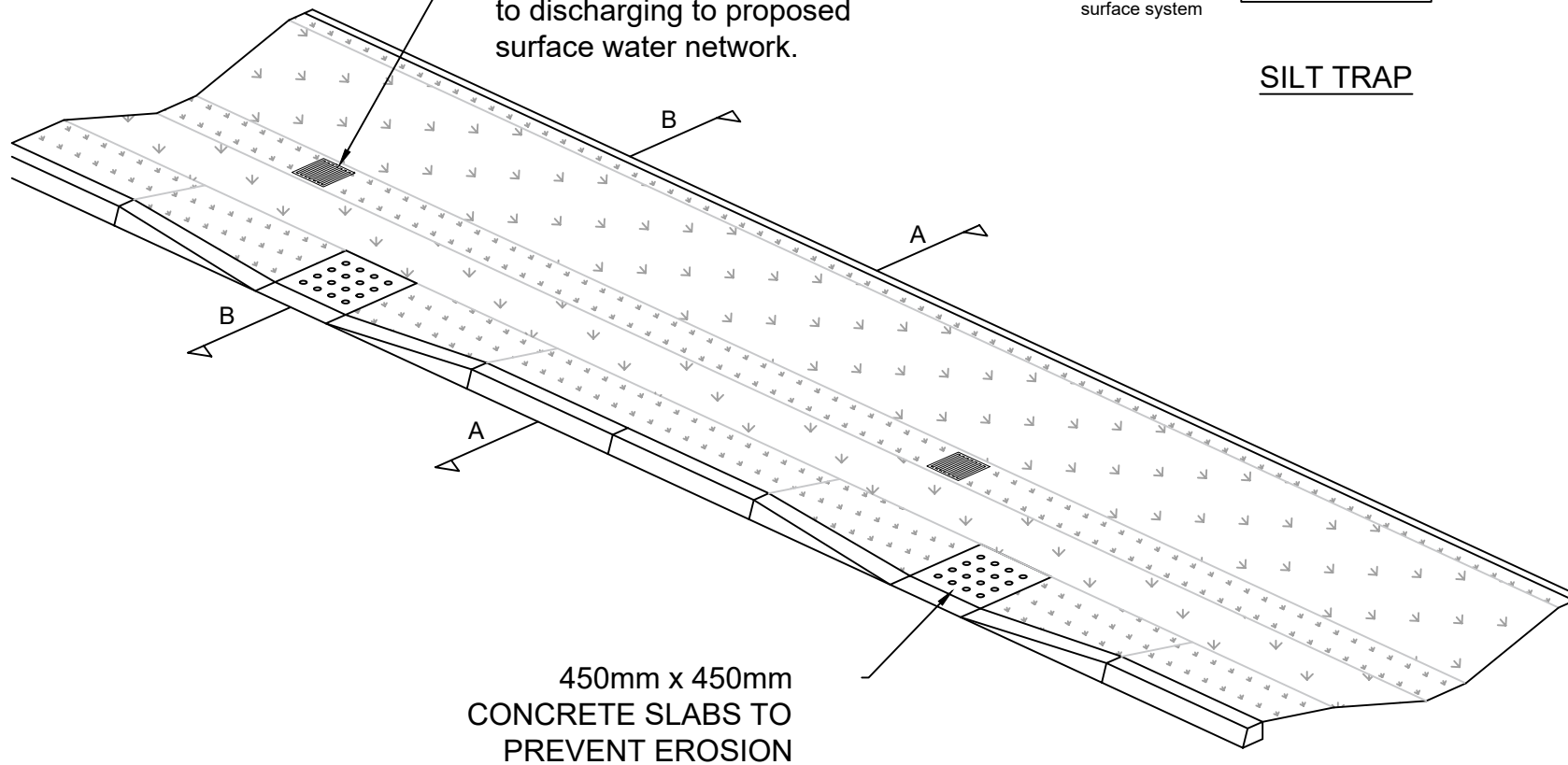

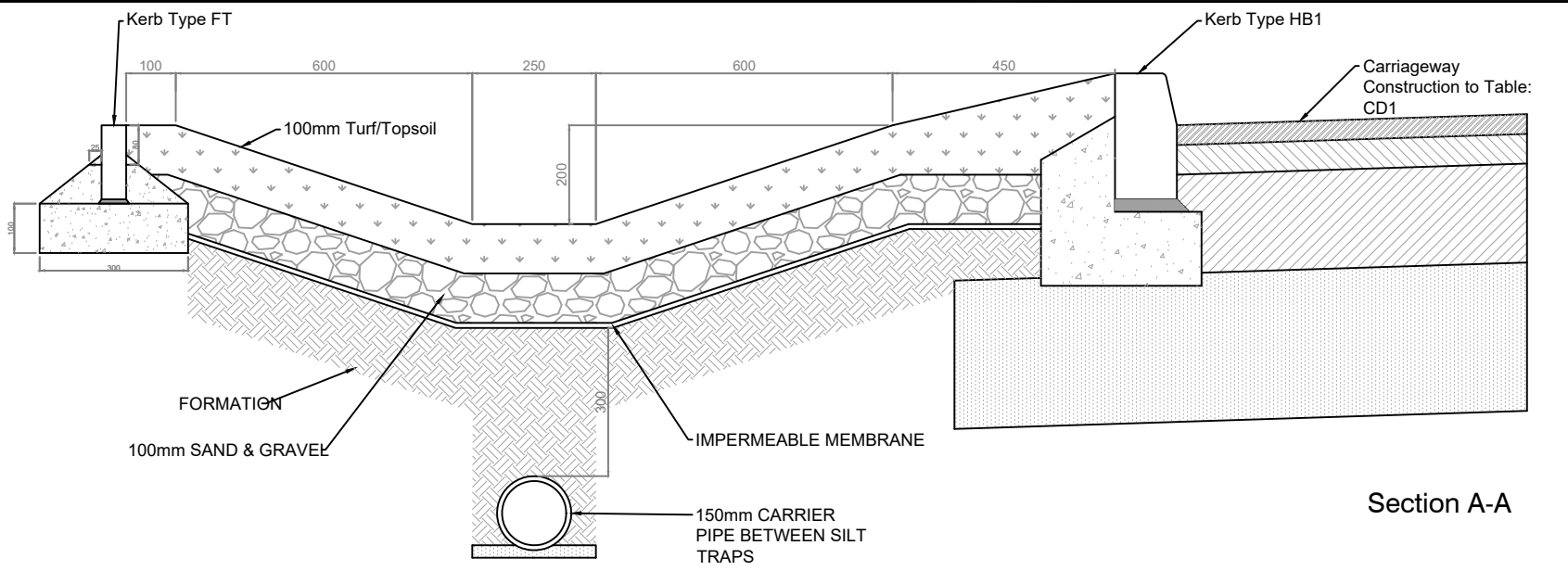



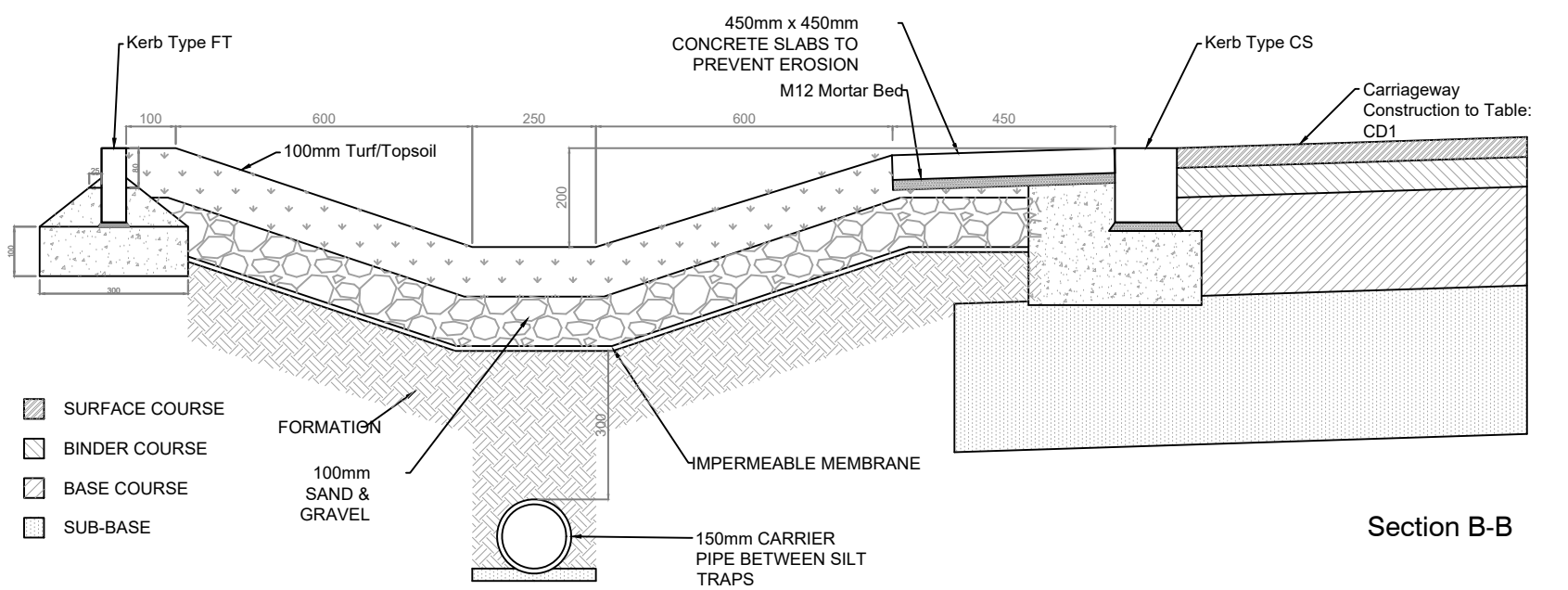

Section A-A



Section B-B

-  SURFACE COURSE
-  BINDER COURSE
-  BASE COURSE
-  SUB-BASE

NOTES

1. All dimensions in millimetres. (This drawing is not to scale)
2. New Kerbing details to comply with drawing as stated
3. Full Construction Information for Carriageway to Table NAC/001/CD

(This drawing is not to scale)



STANDARD WET SWALE/CARRIAGEWAY CONSTRUCTION

COPYRIGHT NORTH AYRSHIRE COUNCIL 2019. USED WITH THE PERMISSION OF NORTH AYRSHIRE COUNCIL FOR DEVELOPMENTS WITHIN NORTH AYRSHIRE ONLY.

DRAWING NO	REV
NAC/318/SWS	A

## NOTES

1. All dimensions in millimetres. (This drawing is not to scale)

(This drawing is not to scale)

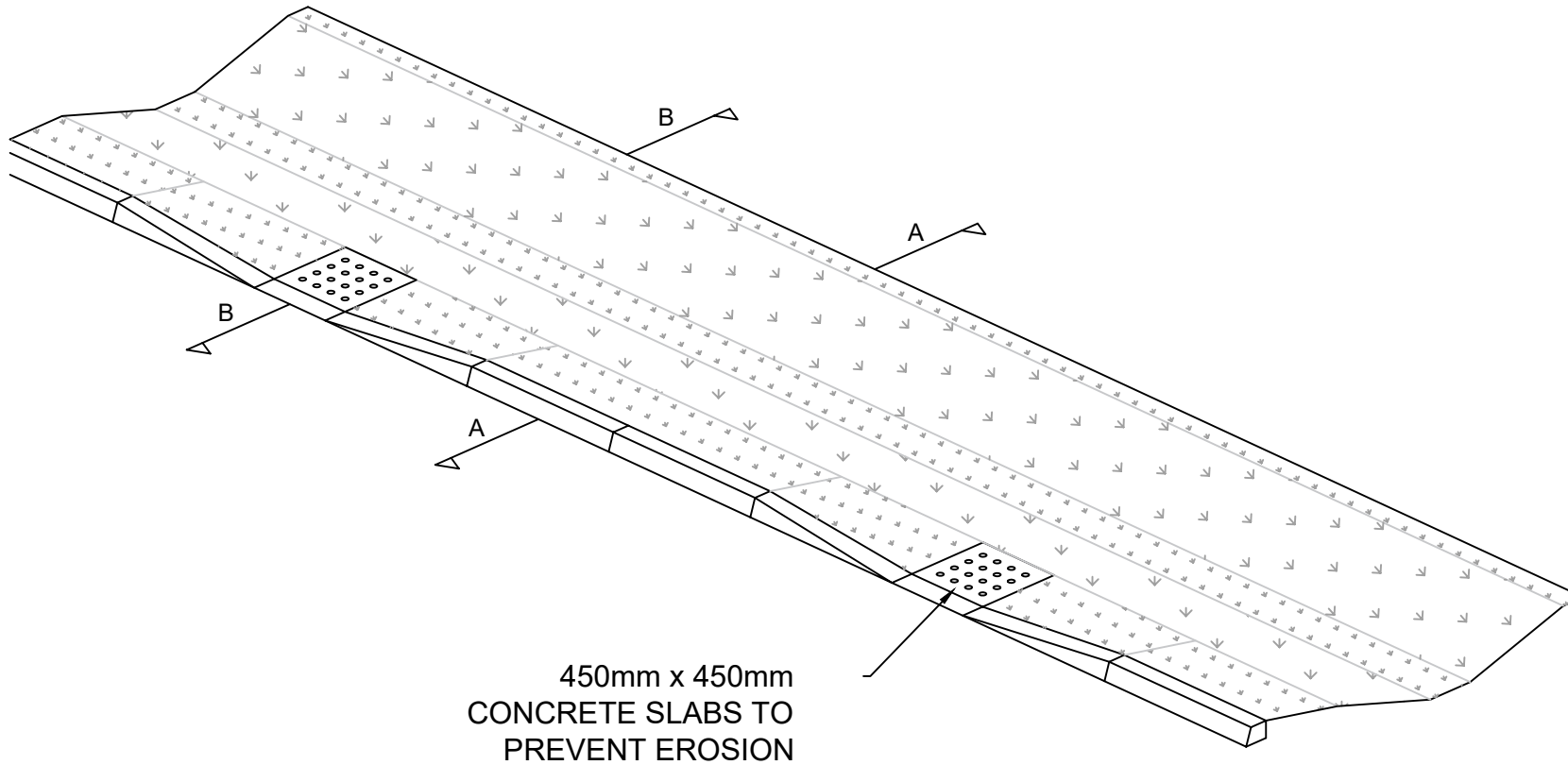

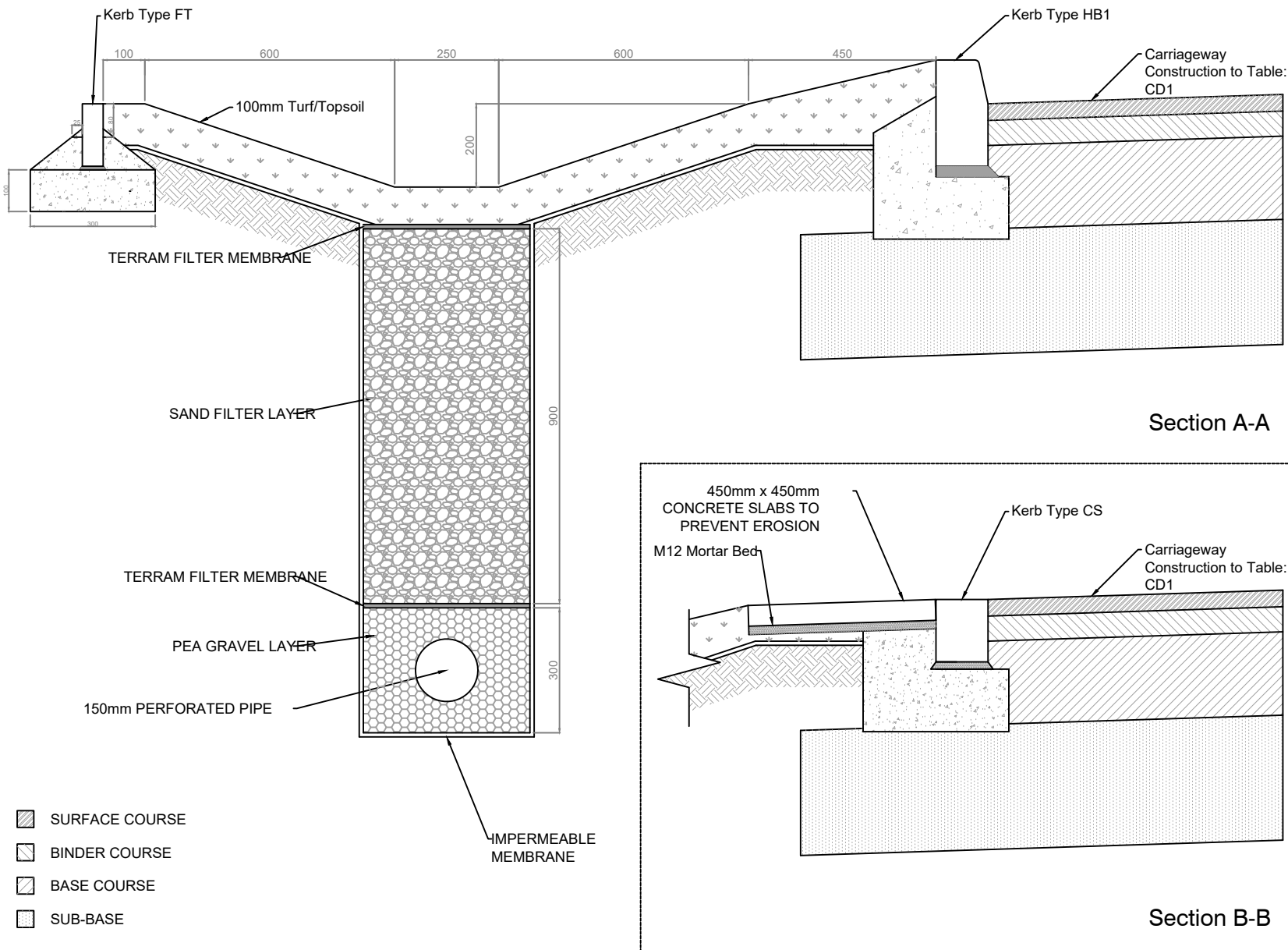

## NOTES

1. All dimensions in millimetres. (This drawing is not to scale)
2. New Kerbing details to comply with drawing as stated
3. Full Construction Information for Carrageaway to Table NAC/001/CD

(This drawing is not to scale)

## NOTES

1. -ll dimensions in millimetres.
2. Precast concrete flags to comply with BS EN 1339:2003.
3. Flags shall be 400mm x 400mm x 50mm thick, coloured red for controlled and buff for uncontrolled.
4. Flags shall only be cut "on the square", and equidistant between rows of surface texturing, except where against a building or fence line.
5. Crossing widths should be chosen, where possible, to avoid the necessity of cut flags.
6. -ll joints shall not be less than 5mm nor more than 10mm width.
7. Joints shall be filled with M12 mortar of a similar colour to the flags and key pointed.
8. For uncontrolled crossings only the two rows next to the kerb will be laid.

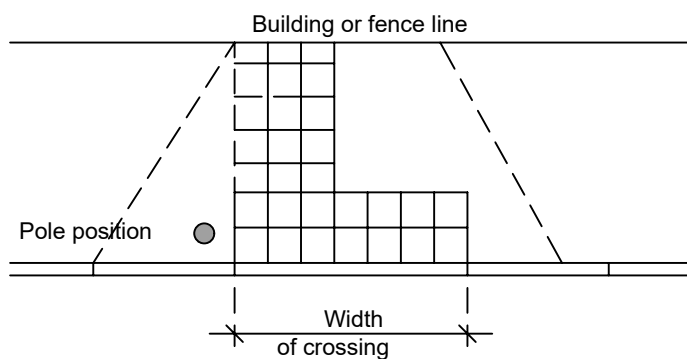
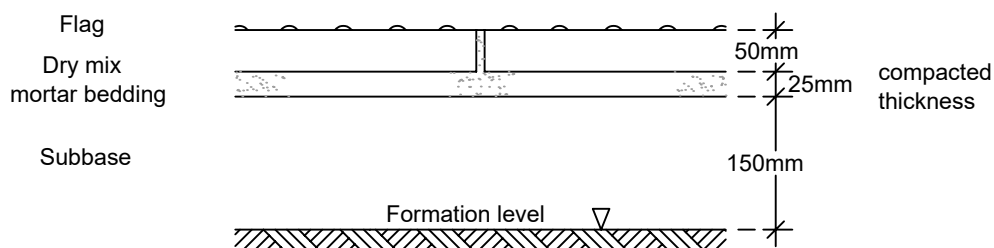

### TYPICAL LAYOUT AT CONTROLLED PEDESTRIAN CROSSING

## NOTES

1. -All dimensions in millimetres.
2. Precast concrete flags to comply with BS EN 1339:2003.
3. Flags shall be 400mm x 400mm x 50mm thick, coloured buff.
4. Flags shall only be cut "on the square", and equidistant between rows of surface texturing, except where against a building or fence line.
5. Crossing widths should be chosen, where possible, to avoid the necessity of cut flags.
6. -All joints shall not be less than 5mm nor more than 10mm width.
7. Joints shall be filled with M12 mortar of a similar colour to the flags and key pointed.

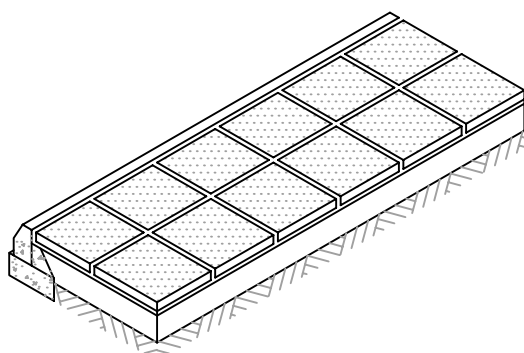

Flag  
Dry mix mortar bedding

Subbase

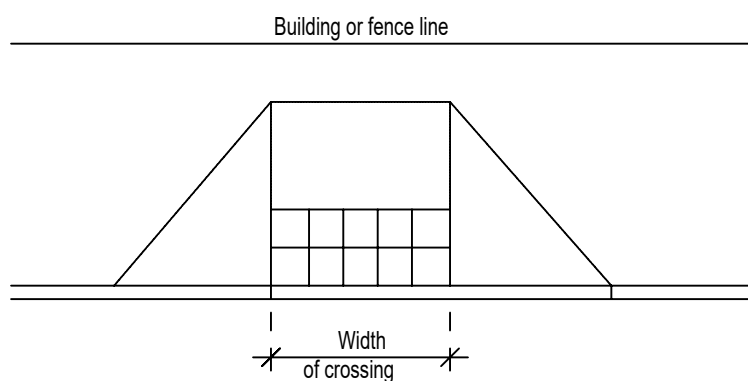
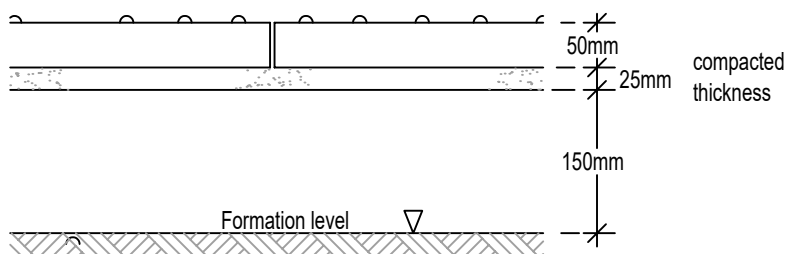

TYPICAL LAYOUT AT DROP KERB CROSSING

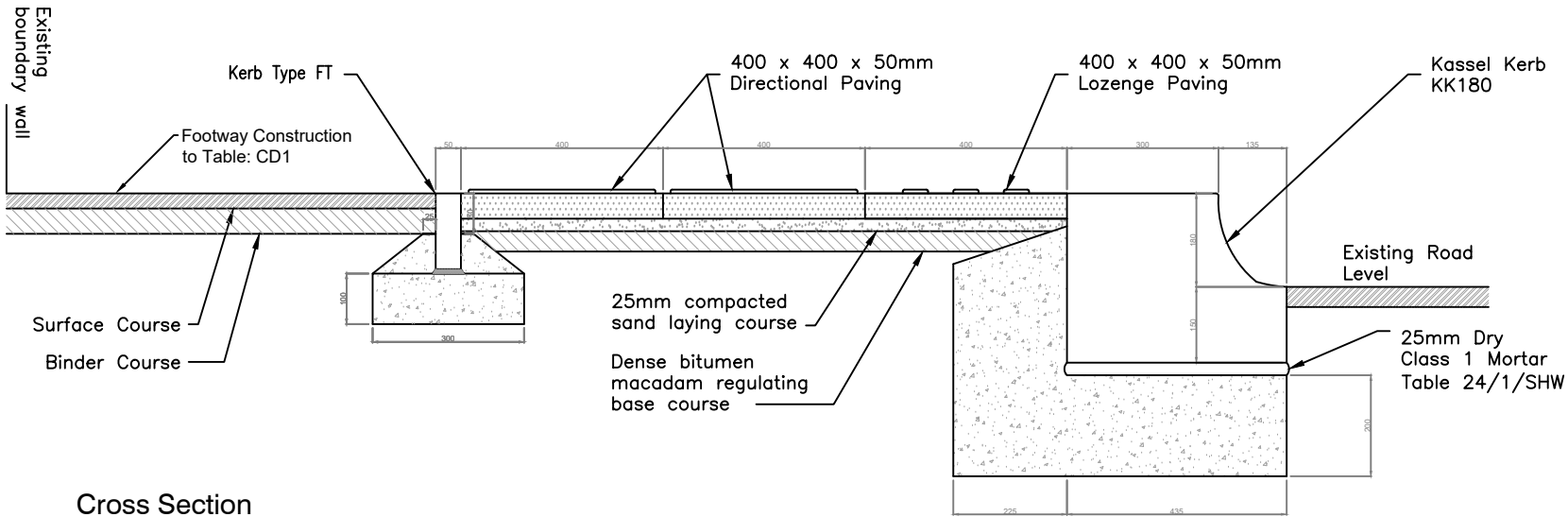

Cross Section

Plan View

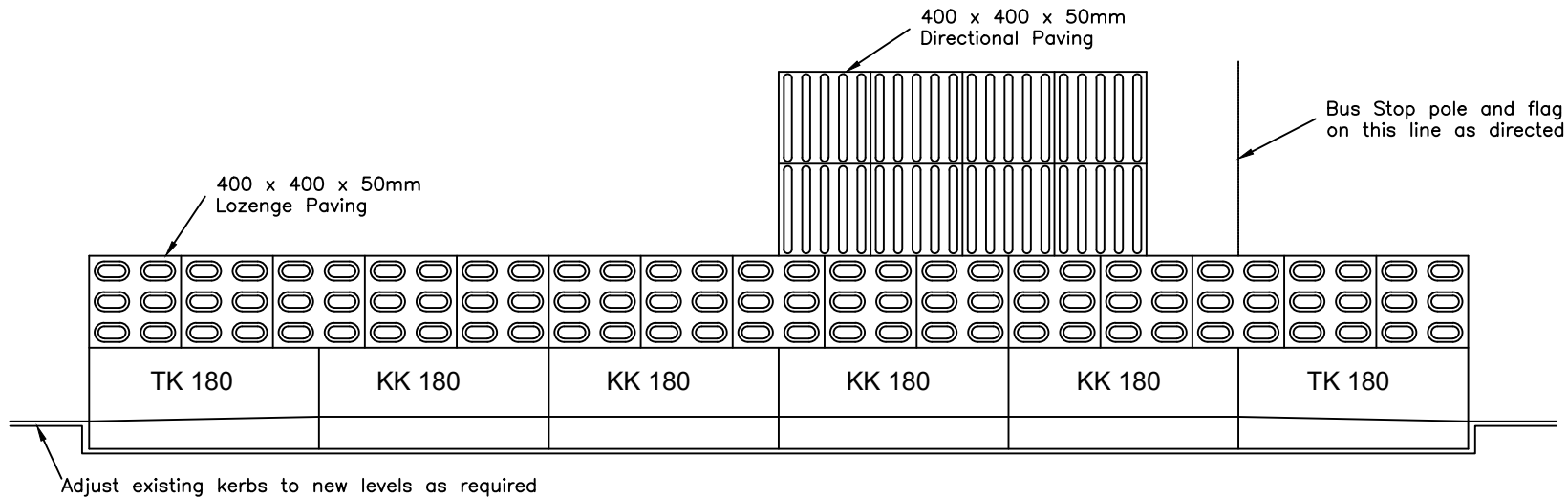

NOTES

1. All dimensions in millimetres. (This drawing is not to scale)
  2. New Kerbing details to comply with drawing as stated
  3. Full Construction Information for Carriageway to Table NAC/001/CD
  4. Full Construction Information for Footway to Table NAC/001/CD
- (This drawing is not to scale)



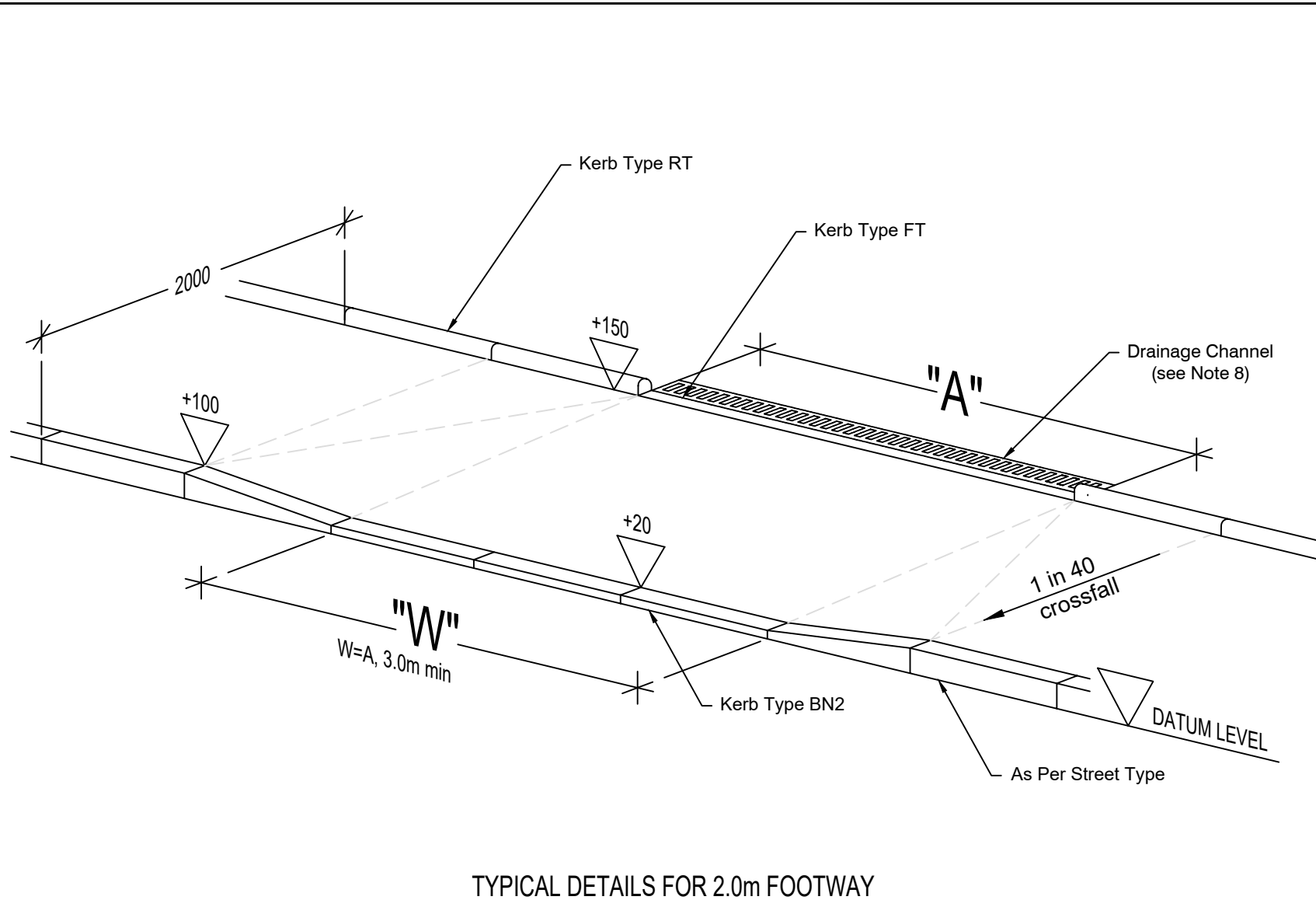

## NOTES

1. All dimensions in millimetres. (This drawing is not to scale)
2. This drawing should be read in conjunction with drawing NAC/205/DW2
3. This access is for vehicular use only. Should provision be required for pedestrians see drawing NAC/409/PCR.
4. Dimension "A" is the width of the access.
5. Dimension "W" is the width of the drop crossing.
6. New Kerbing details to comply with drawing as stated
7. Full Construction Information for Footway to Table NAC/001/CD
8. Where the gradient of the Private Driveway slopes towards the Public Footway, a Drainage Channel as depicted must be installed. It is not required if the Private Driveway slopes into the private grounds.

(This drawing is not to scale)

## NOTES

1. All dimensions in millimetres. (This drawing is not to scale)
2. This access is for vehicular use only. Should provision be required for pedestrians see drawing NAC/409/PCR.
3. Dimension "A" is the width of the access.
4. Dimension "W" is the width of the drop crossing.
5. New Kerbing details to comply with drawing as stated
6. Footway Crossing to match Full Construction Information for Carriageway to Table NAC/001/CD
7. Full Construction Information for Footway to Table NAC/001/CD

(This drawing is not to scale)

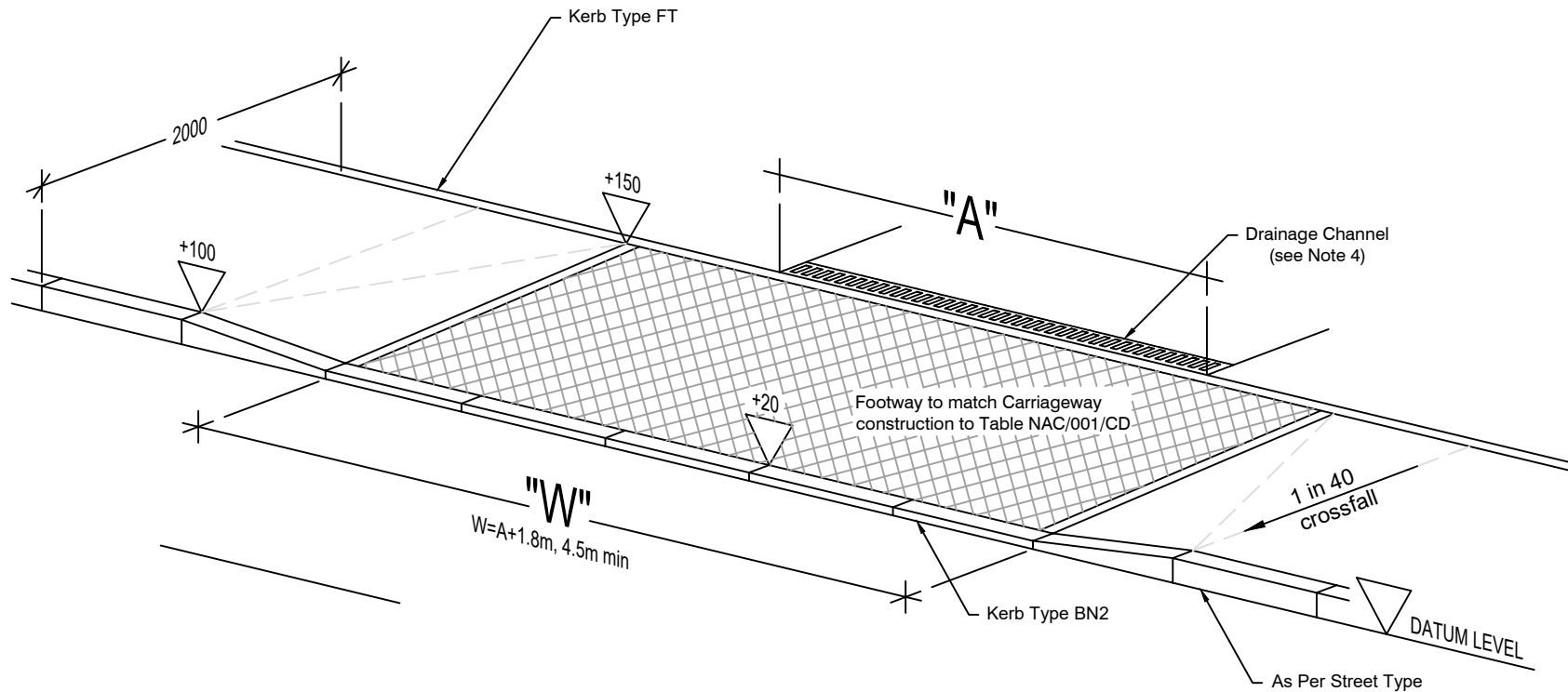

TYPICAL DETAILS FOR 2.0m FOOTWAY

## NOTES

1. All dimensions in millimetres. (This drawing is not to scale)
2. This access is for vehicular use only. Should provision be required for pedestrians see drawing NAC/409/PCR.
3. Dimension "A" is the width of the access road.  
MINIMUM - 5.5m Car Park  
- 6.0m Commercial
4. Dimension "R" is the corner radius.  
MINIMUM - 4.5m Car Park  
- 6.0m Commercial
5. New Kerbing details to comply with drawing as stated
6. Footway Crossing to match Full Construction Information for Carriageway to Table NAC/001/CD
7. Full Construction Information for Footway to Table NAC/001/CD

(This drawing is not to scale)

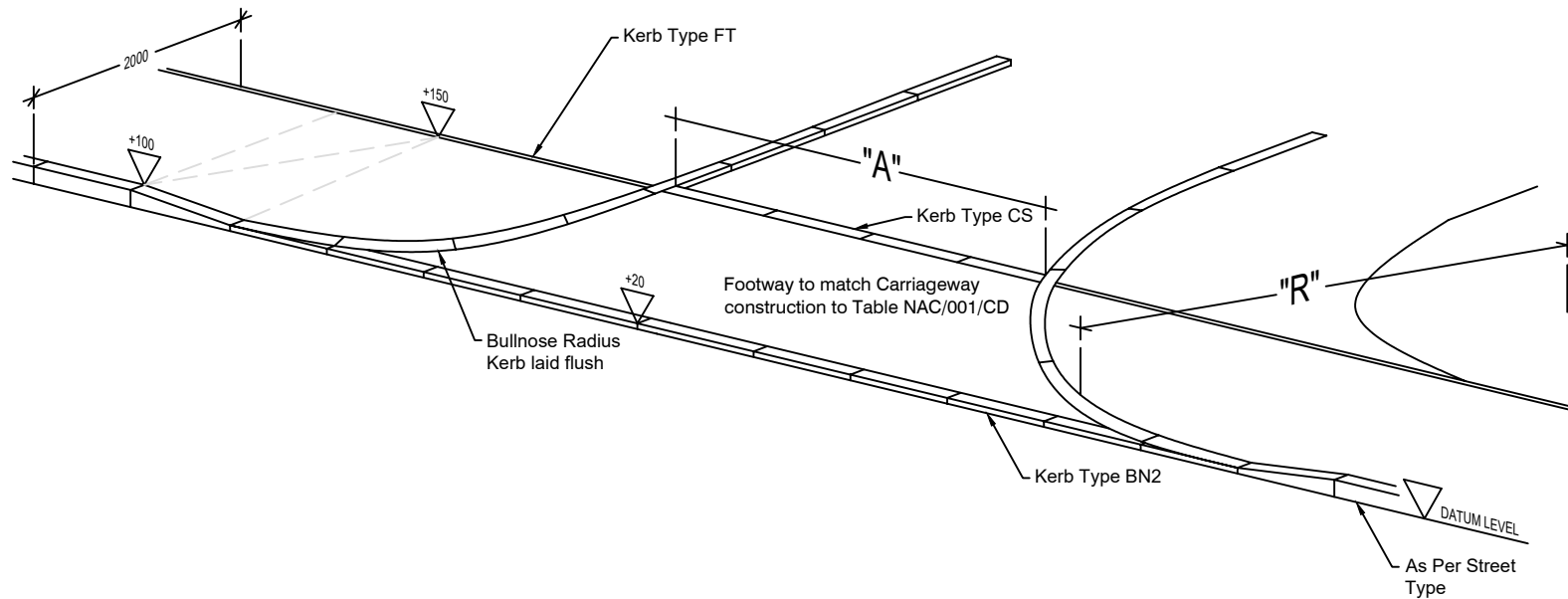

## NOTES

1. All dimensions in millimetres. (This drawing is not to scale)
2. This access is for vehicular use only. Should provision be required for pedestrians see drawing NAC/409/PCR.
3. Dimension "A" is the width of the access road.  
MINIMUM - 6.0m Non-Industrial  
- 7.3m Industrial
4. Dimension "R" is the corner radius.  
MINIMUM - 6.0m Non-Industrial  
- 9.0m Industrial
5. New Kerbing details to comply with drawing as stated
6. Footway Crossing to match Full Construction Information for Carriageway to Table NAC/001/CD
7. Full Construction Information for Footway to Table NAC/001/CD

(This drawing is not to scale)

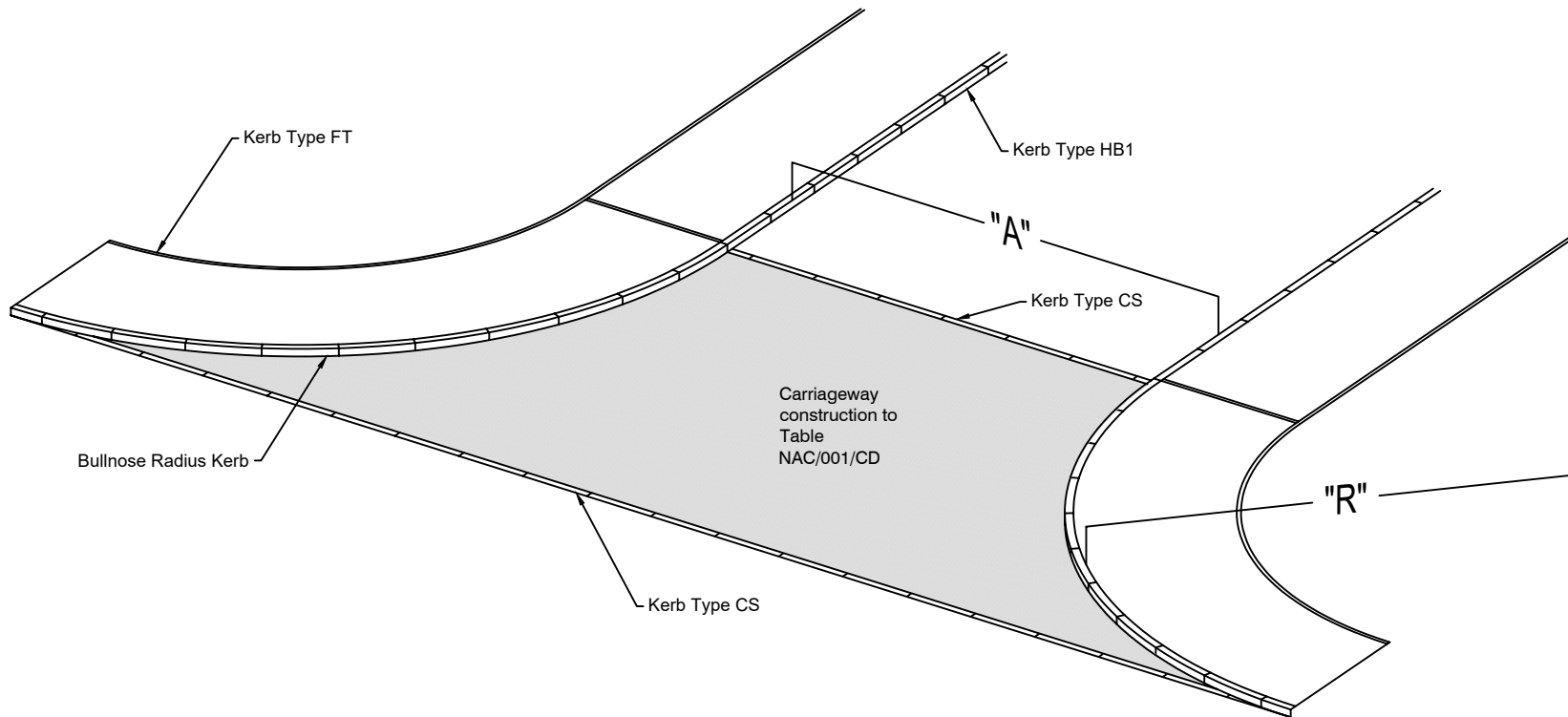

## MAJOR COMMERCIAL ACCESS

## NOTES

1. All dimensions in metres. (This drawing is not to scale)
2. This drawing should be read in conjunction with drawings NAC/404/DW1, NAC/205/DW2 and NAC/206/DW3
3. This access is for vehicular use only. Should provision be required for pedestrians see drawing NAC/409/PCR.
4. Private driveways should normally meet the road at right angles at dropped kerb access
5. Unless giving direct access to a garage, driveways should be at least 12 metres long. This will facilitate the future construction of garages.
6. In order to be accepted as a dwellings allocated parking space, a garage must meet a minimum internal dimension of 6m x 3m.
7. The minimum width of driveways should be 2.75 metres with widening required on narrow carriageways;  
 CW over 5m = 2.75m min  
 CW 5m to 3.5m = 3.0m min  
 CW 3.5m or less = 3.2m min
8. A width of 4.5 metres will accommodate a parked car with sufficient space to allow access.
9. Double width parking can be accommodated on a 4.8 metres wide driveway; however, wheelchair or perambulator access may not be possible in these circumstance and therefore consideration should also be given to providing a segregated pedestrian access or local widening of the driveway.
10. The length of double driveways required in front of a garage to accommodate a parked vehicle and access to the garage should be a minimum of 10.5 metres.
11. Full Construction Information for Carriageway to Table NAC/001/CD
12. Full Construction Information for Footway to Table NAC/001/CD

(This drawing is not to scale)

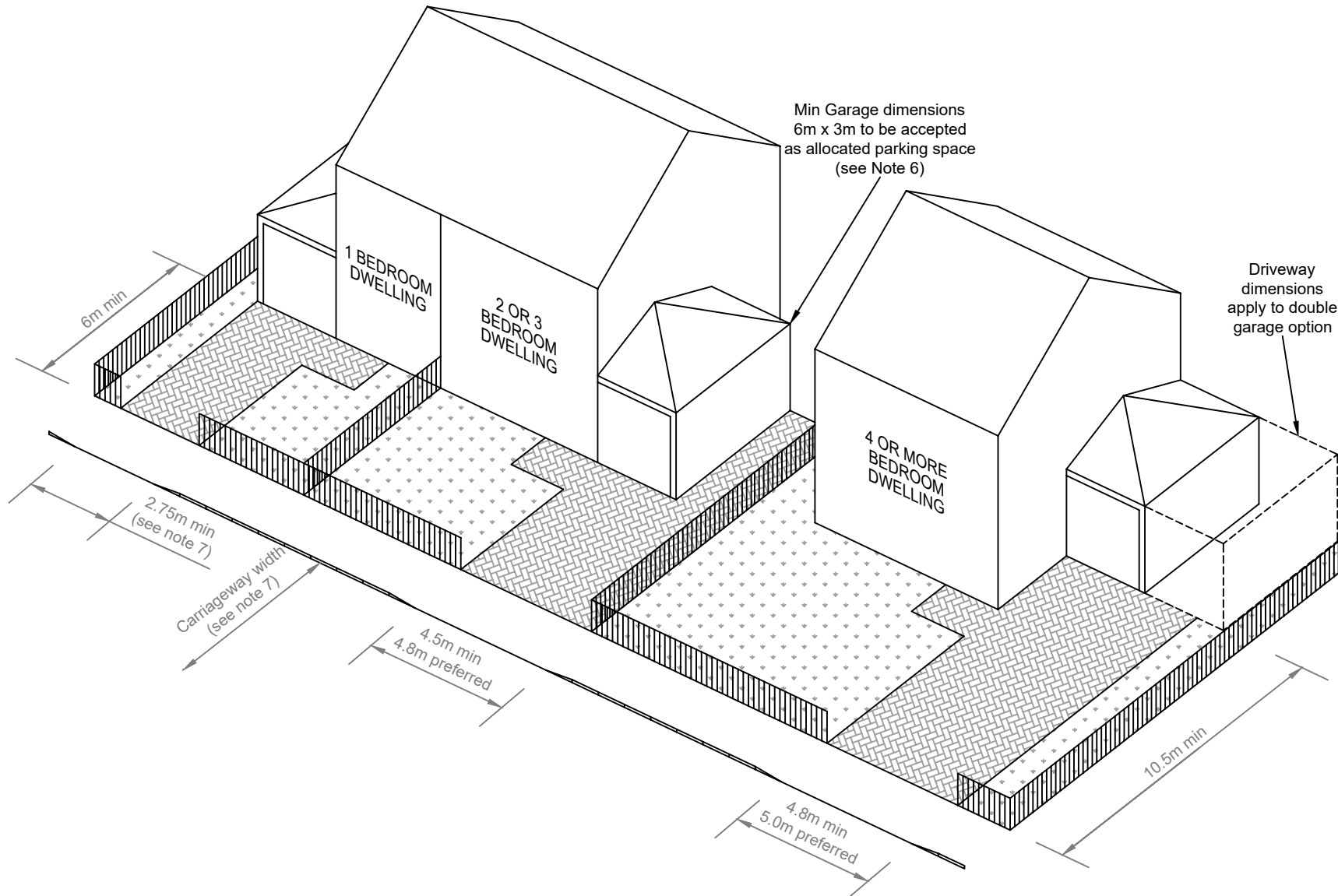

## MINIMUM DRIVEWAY DIMENSIONS

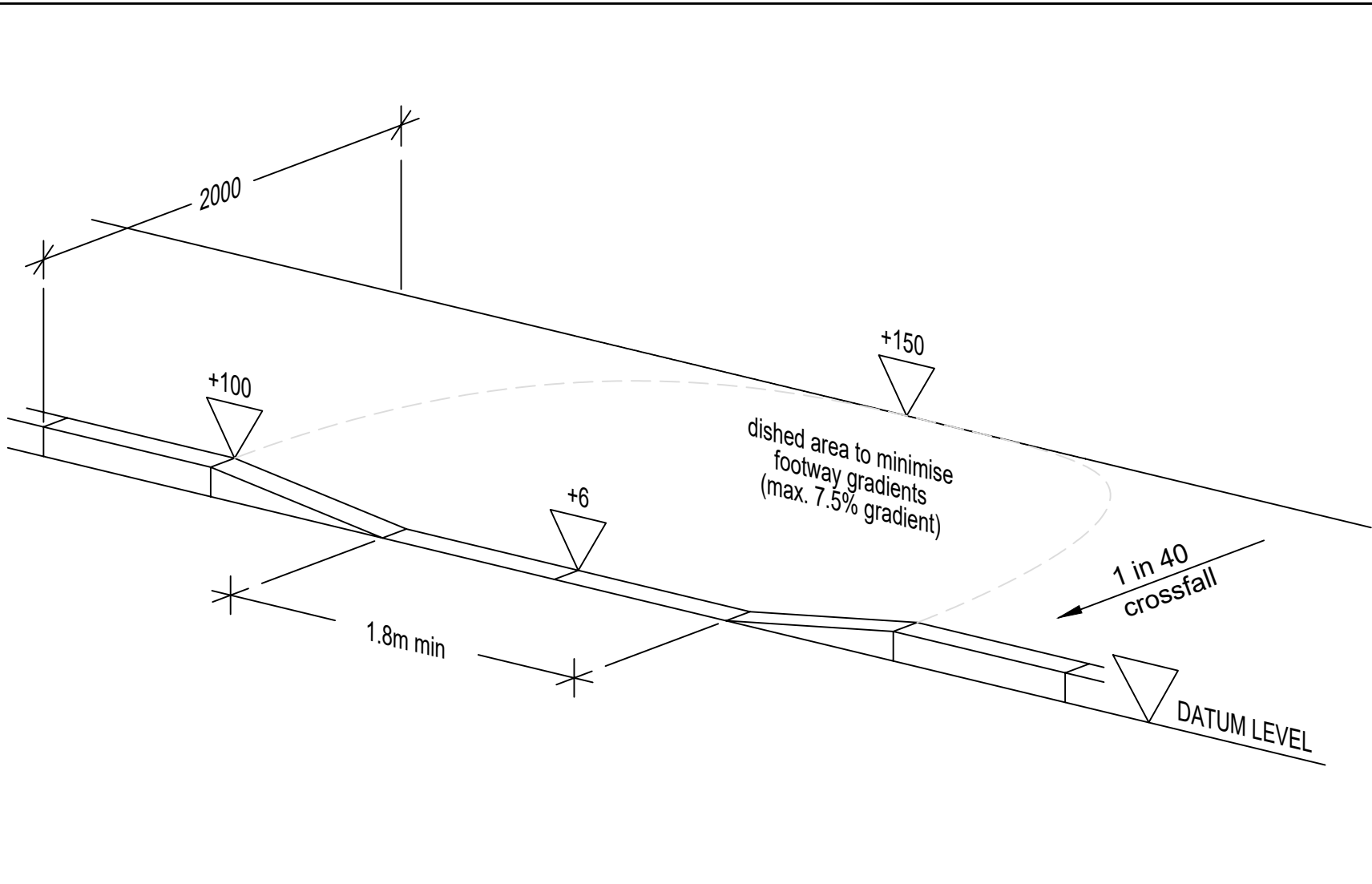

TYPICAL DETAILS FOR 2.0m FOOTWAY

## NOTES

1. All dimensions in millimetres. (This drawing is not to scale)
2. New Kerbing details to comply with drawing as stated
3. Full Construction Information for Carriageway to Table NAC/001/CD
4. Full Construction Information for Footway to Table NAC/001/CD

(This drawing is not to scale)

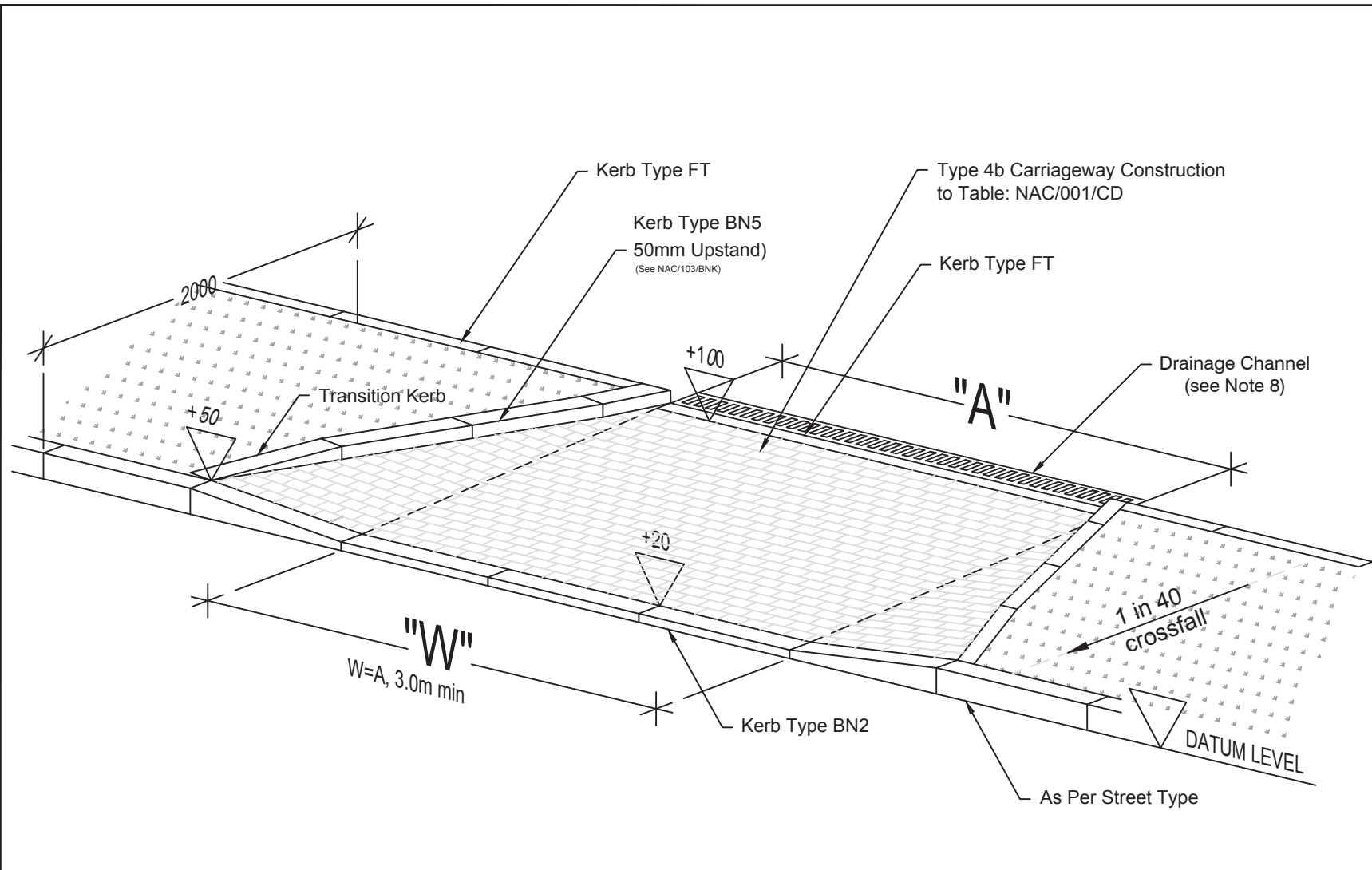

TYPICAL DETAILS FOR 2.0m SERVICE STRIP

NOTES

1. All dimensions in millimetres. (This drawing is not to scale)
2. This drawing should be read in conjunction with drawing NAC/206/DW3
3. This access is for vehicular use only. Should provision be required for pedestrians see drawing NAC/409/PCR.
4. Dimension "A" is the width of the access.
5. Dimension "W" is the width of the drop crossing.
6. New Kerbing details to comply with drawing as stated
7. Full Construction Information for Footway to Table NAC/001/CD
8. Where the gradient of the Private Driveway slopes towards the Public Footway, a Drainage Channel as depicted must be installed. It is not required if the Private Driveway slopes into the private grounds.

(This drawing is not to scale)



STANDARD PRIVATE DRIVEWAY ACCESS (SERVICE STRIP)

COPYRIGHT NORTH AYRSHIRE COUNCIL 2019. USED WITH THE PERMISSION OF NORTH AYRSHIRE COUNCIL FOR DEVELOPMENTS WITHIN NORTH AYRSHIRE ONLY.

DRAWING NO	REV
NAC/410/DW4	B

## NOTES

1. All dimensions in millimetres.

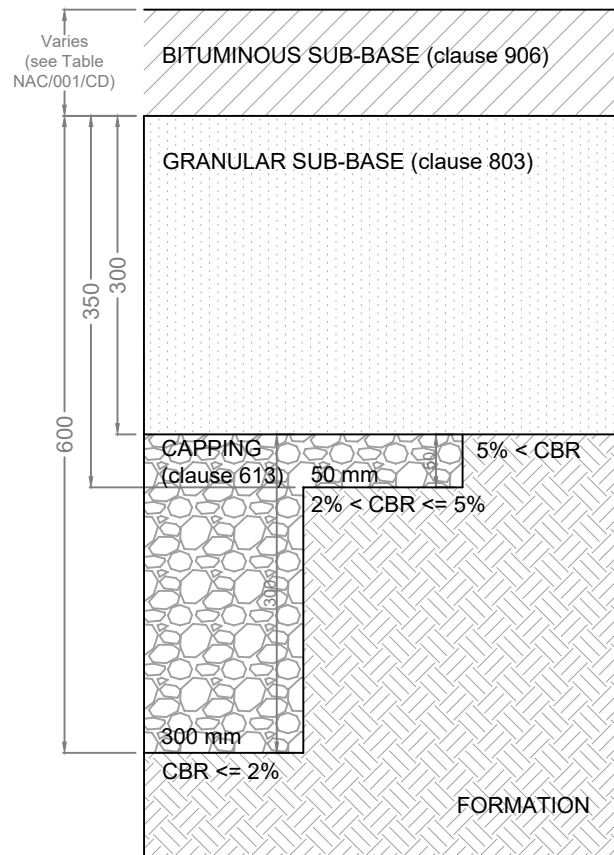

For a  $2\% < \text{CBR} \leq 5\%$  where the total bituminous thickness and sub-base thickness together are less than 450mm, the sub-base is increased to achieve 450mm of non frost susceptible material and the capping layer can be correspondingly reduced. This need not be done if the capping layer is non frost-susceptible.

Although the table gives various thicknesses of capping layer dependent upon CBR, where CBR is significantly below 2%, these thicknesses may require to be increased dependent upon site and weather conditions prevailing at the time of construction. Additional material may require to be removed and replaced by more suitable material. Although the new material may be of good quality, the subgrade shall be assumed to be equivalent to one of a CBR just under 2% and requiring 300 mm of capping layer. The developer should consult the Network Manager for advice in these circumstances.

Where suitable technical facilities exist, it is recommended that the specific circumstances of each site are catered for by designing the road in accordance with the criteria stipulated above, Subject to a minimum construction as required to carry 0.5 Million Standard Axles (MSA), for all roads. In this circumstance it will be necessary to complete and return form CCS "Carriageway Design Certificate".



# NOTES

1. All dimensions in millimetres. (This drawing is not to scale)
2. Ensure reflective banding is in the correct orientation - RED towards oncoming traffic.
3. The reinforcing tube or anchor bar is to be orientated so that the coupling bolt is inserted at 90° to the carriageway (see Plan view).
4. The reinforcing tube should be filled with concrete where required for additional strength.

(This drawing is not to scale)

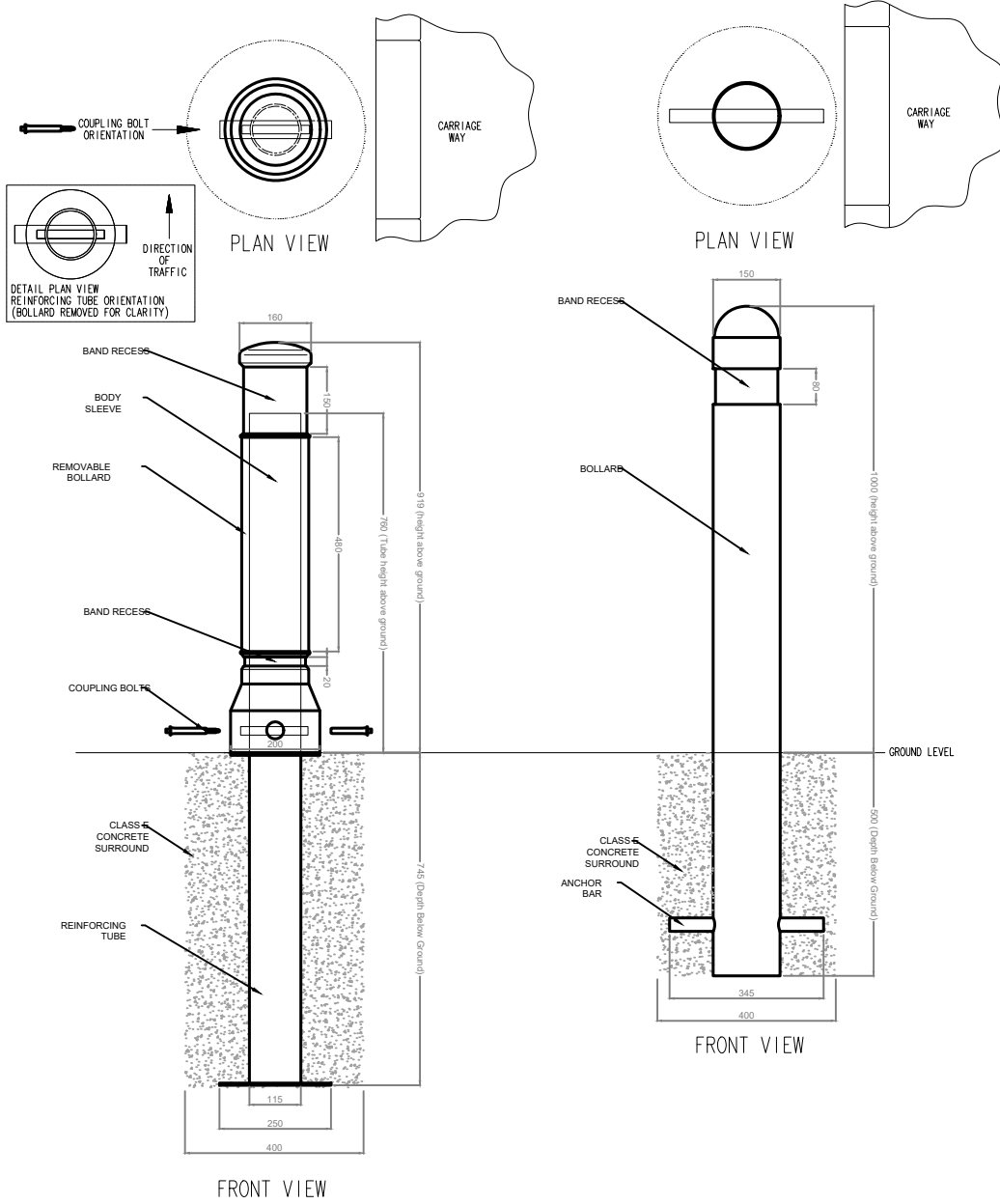

NEOPOLITAN 150

ENVIROPOL

DRAWING NO	REV
NAC/502/BOL	A

## NOTES

1. All dimensions in millimetres.

### SECTION

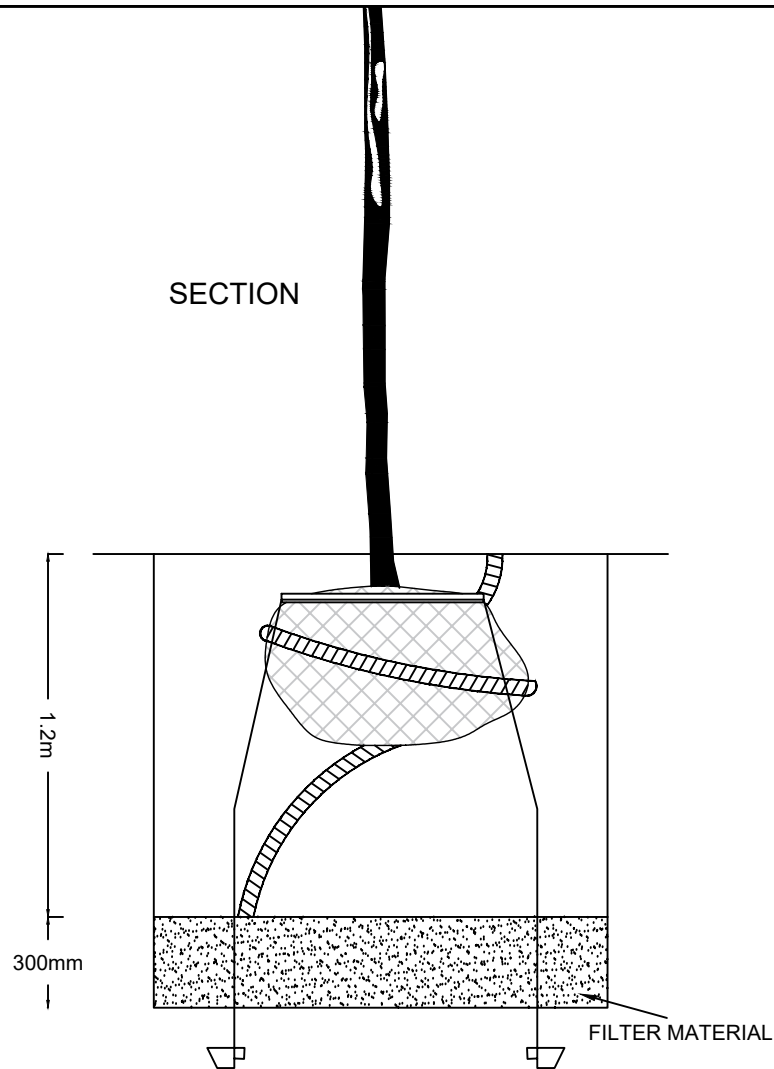

### PLAN

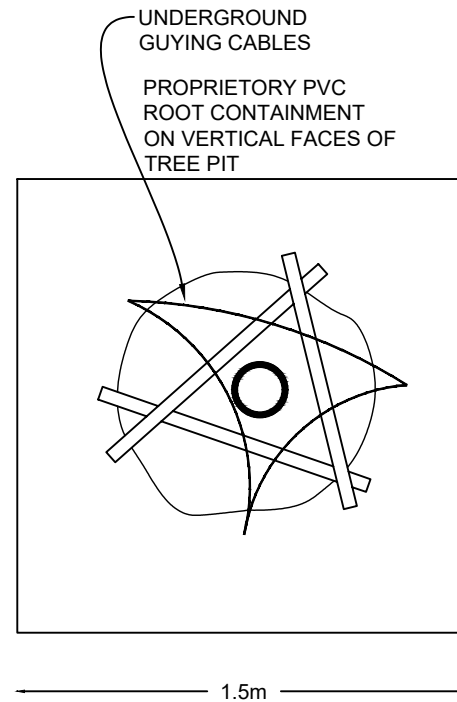

NOTE: FILTER MATERIAL REQUIRED ABOVE IMPERVIOUS GROUND CONDITIONS  
FLEXIBLE ROOT LINER ALTERNATIVE TO CONCRETE RING

## NOTES

1. All dimensions in millimetres. (This drawing is not to scale)
2. Full Construction Information for Carriageway to Table NAC/001/CD
3. All bituminous joints to be treated to SHW cl 903, Sections 21-25
4. Bond Coat/Tack Coat to SHW cl 920

(This drawing is not to scale)

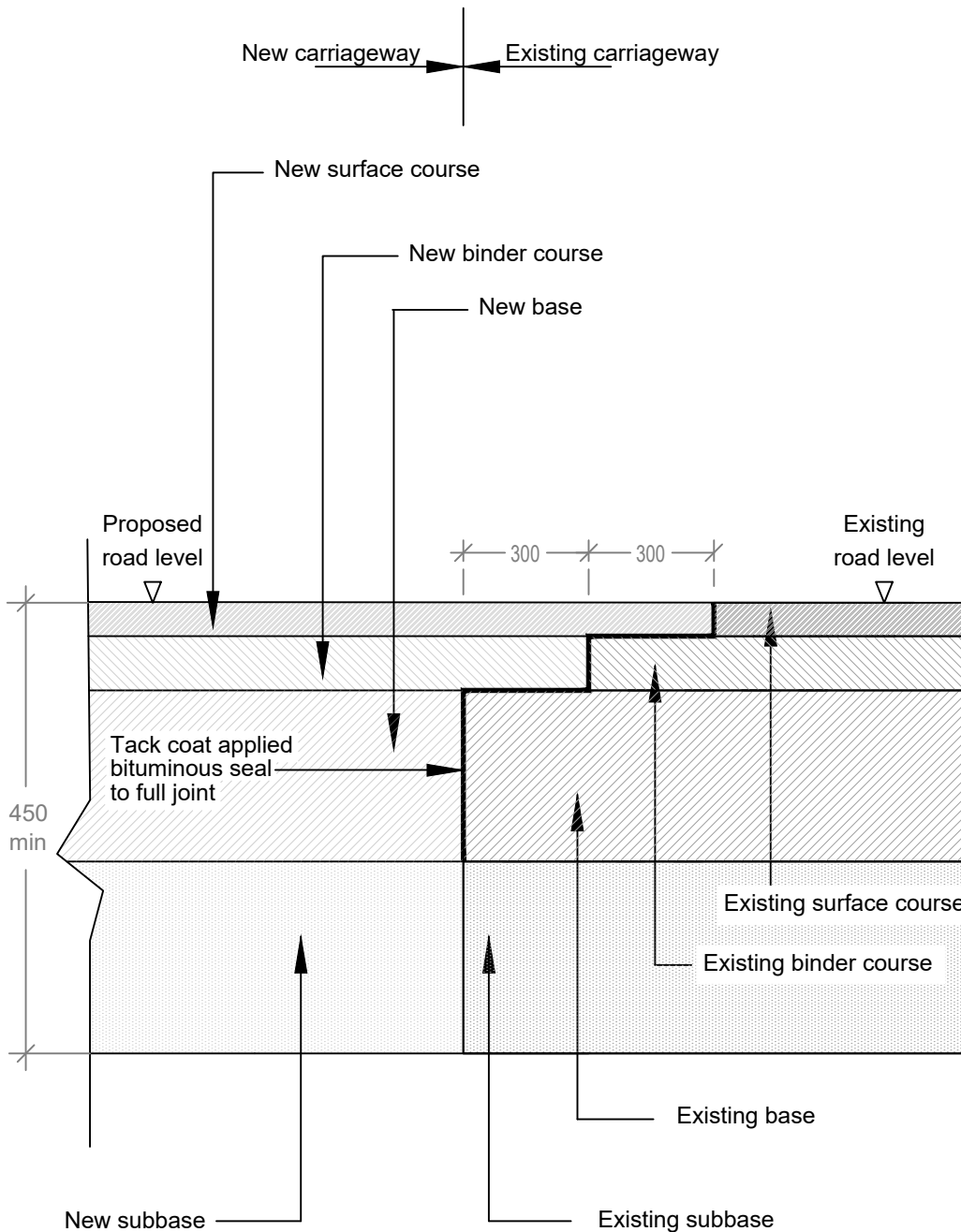

## NOTES

1. All dimensions in millimetres.
2. The Specification for road traffic signs and posts shall be laid down in the following documents:
  - (a) BS EN 12899-1:2007: "Fixed, vertical road traffic signs", as amended.
  - (b) The Traffic Signs Regulations and General Directions 2016.
  - (c) The Traffic Signs Manual, as amended.
  - (d) The Manual of Contract Documents for Highway Works, as amended.
3. Traffic sign posts shall be manufactured to the dimension stated in the Schedule of Items and comply with the requirements of BS EN 12899-1:2007.
4. They shall be tubular hollow sections complying with BS EN 10210 and shall be manufactured from galvanised steel and coated with PVC complying with BS EN12899-1:2007.
5. The posts shall be new continuous lengths with no welded sections or change in external diameter other than between base section and shaft.
5. Post doors shall have a galvanised 3mm nominal diameter closed link stainless steel chain attached to the column sufficiently long to allow the door to rest freely on the ground when the post is erected in its operational position.
6. Brass or stainless steel earthing terminals shall be provided on the posts (posts with flare bases only) and post door, size M8 x 30mm long complete with two brass or stainless steel hexagon nuts and two plain brass or stainless steel washers. These shall be welded or brazed to the access doors and inside walls of the base compartment and shall be fitted with a distinctly and durably marked metal label marked: SAFETY ELECTRICAL CONNECTION - DO NOT REMOVE.
7. The post manufacturer shall be registered with and certified by either British Standards Institute Quality Assurance Services, Lloyds Register Quality Assurance Limited or other Nationally Approved Body for the manufacture, supply and verification of traffic sign posts under their Quality Assessment Schedule to ISO 9001.
8. Concrete for posts will be Class ST5

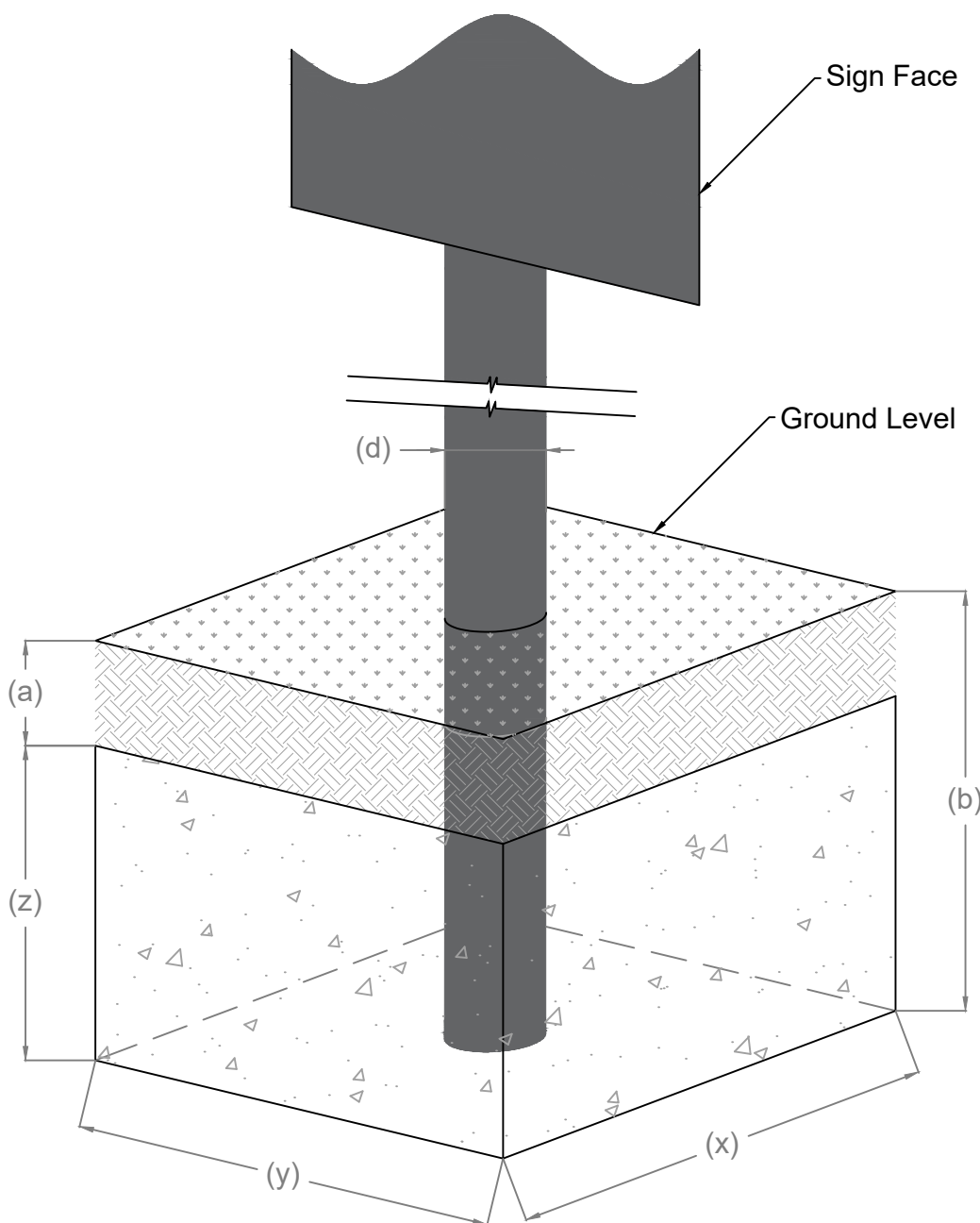

Pole Diameter (d)	Base Length (x)	Base Width (y)	Base Depth (z)	Cover to Base (a)	Planting Depth (b)
76	600	600	450	150	600
89	600	600	600	150	750
114	900	600	600	150	750
140	1200	750	750	150	900

(All dimensions in millimetres)

## SIGNPOST FOUNDATION DETAIL

COPYRIGHT NORTH AYRSHIRE COUNCIL 2019. USED WITH THE PERMISSION OF NORTH AYRSHIRE COUNCIL FOR DEVELOPMENTS WITHIN NORTH AYRSHIRE ONLY.

## NOTES

1. All dimensions in millimetres. (This drawing is not to scale)
2. Street nameplate to be non-reflective, helvetica medium lettering, black on white background on 3mm aluminium plate, rounded corners and 8mm black border. Sealed with appropriate weatherproof clear protective material. Lettering to be 75mm, uppercase, and on two or more lines if appropriate.
3. Street nameplate to be mounted using rivited channel rails and 4x76mm stainless steel anti-rotational clips, plus 2x76mm diameter grey PVC material coated poles, bitumen coated internal surfaces, galvanised base plates, plastic pole caps to allow mounting height of 1.0m and foundation depth of 500mm.
4. Poles to be fitted in 300mm x 300mm x 500mm deep hole, ancillary concrete mix ST2 or similar approved mix, concrete foundations to be float finished flush with existing hard surfaces, and painted with bitumen paint to match. Soft soil, verge, turf etc. to be reinstated to original surface, where appropriate on top of concrete foundation.

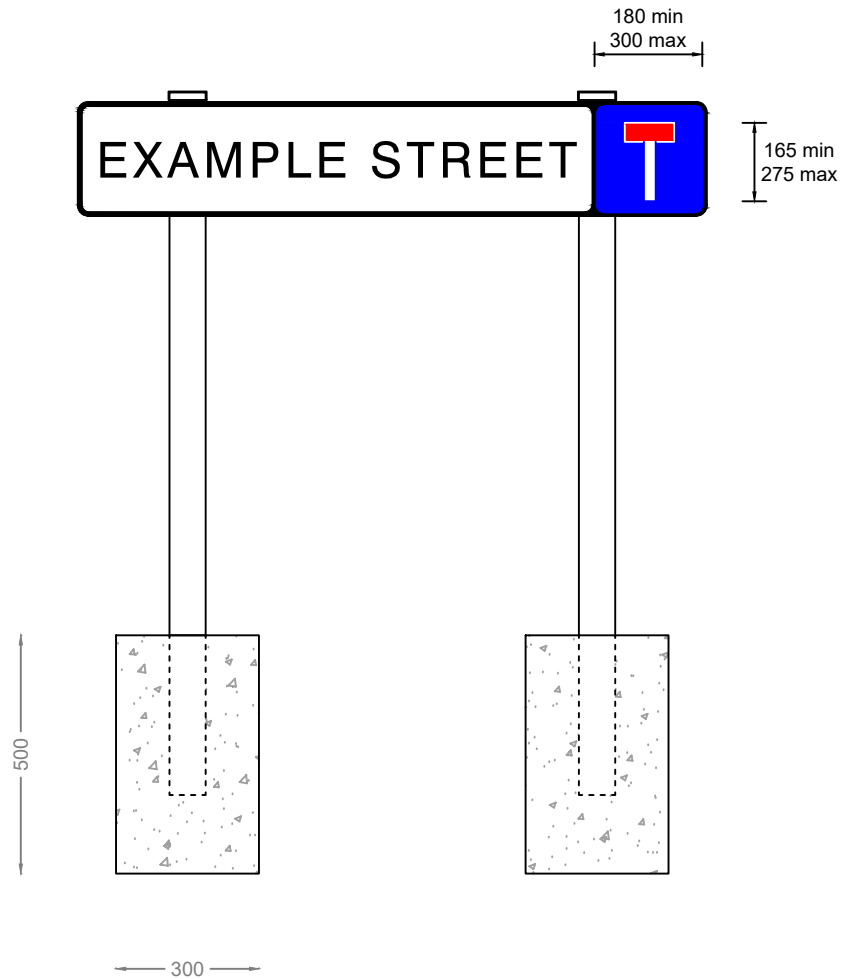

## STREET NAMEPLATE DETAIL